



Gasoline from Wood via Integrated Gasification, Synthesis, and Methanol-to- Gasoline Technologies

Steven D. Phillips, Joan K. Tarud, Mary J. Bidy,
and Abhijit Dutta

NREL is a national laboratory of the U.S. Department of Energy, Office of Energy Efficiency & Renewable Energy, operated by the Alliance for Sustainable Energy, LLC.

Technical Report
NREL/TP-5100-47594
January 2011

Contract No. DE-AC36-08GO28308

Gasoline from Wood via Integrated Gasification, Synthesis, and Methanol-to- Gasoline Technologies

Steven D. Phillips, Joan K. Tarud, Mary J. Bidy,
and Abhijit Dutta

Prepared under Task No. BB07.3710

**NREL is a national laboratory of the U.S. Department of Energy, Office of Energy
Efficiency & Renewable Energy, operated by the Alliance for Sustainable Energy, LLC.**

NOTICE

This report was prepared as an account of work sponsored by an agency of the United States government. Neither the United States government nor any agency thereof, nor any of their employees, makes any warranty, express or implied, or assumes any legal liability or responsibility for the accuracy, completeness, or usefulness of any information, apparatus, product, or process disclosed, or represents that its use would not infringe privately owned rights. Reference herein to any specific commercial product, process, or service by trade name, trademark, manufacturer, or otherwise does not necessarily constitute or imply its endorsement, recommendation, or favoring by the United States government or any agency thereof. The views and opinions of authors expressed herein do not necessarily state or reflect those of the United States government or any agency thereof.

Available electronically at <http://www.osti.gov/bridge>

Available for a processing fee to U.S. Department of Energy and its contractors, in paper, from:

U.S. Department of Energy
Office of Scientific and Technical Information

P.O. Box 62
Oak Ridge, TN 37831-0062
phone: 865.576.8401
fax: 865.576.5728
email: <mailto:reports@adonis.osti.gov>

Available for sale to the public, in paper, from:

U.S. Department of Commerce
National Technical Information Service
5285 Port Royal Road
Springfield, VA 22161
phone: 800.553.6847
fax: 703.605.6900
email: orders@ntis.fedworld.gov
online ordering: <http://www.ntis.gov/help/ordermethods.aspx>

Cover Photos: (left to right) PIX 16416, PIX 17423, PIX 16560, PIX 17613, PIX 17436, PIX 17721



Printed on paper containing at least 50% wastepaper, including 10% post consumer waste.

Executive Summary

This report documents the National Renewable Energy Laboratory's (NREL's) assessment of the feasibility of making gasoline via the methanol-to-gasoline (MTG) route using syngas from a 2,000 dry metric tonne/day (2,205 U.S. ton/day) biomass-fed facility.

The thermochemical route of biomass gasification produces a syngas rich in hydrogen and carbon monoxide. The syngas is then converted into methanol, and the methanol is converted to gasoline using the methanol-to-gasoline (MTG) process first developed by Exxon Mobil. Using a methodology similar to that used in previous NREL design reports and a feedstock cost of \$50.70/dry U.S. ton (\$55.89/dry metric tonne), a plant gate price (PGP) was estimated. For the base case the PGP is predicted to be \$16.60/MMBtu (\$15.73/GJ) (U.S. \$2007) for gasoline and liquefied petroleum gas (LPG) produced from biomass via gasification of wood, methanol synthesis, and the methanol-to-gasoline process (MTG). The corresponding unit prices for gasoline and LPG are \$1.95/gallon (\$0.52/liter) and \$1.53/gallon (\$0.40/liter) with yields of 55.1 and 9.3 gallons per U.S. ton of dry biomass (229.9 and 38.8 liters per metric tonne of dry biomass), respectively. For comparison to ethanol, this is \$1.39 per gallon (\$0.37/liter) ethanol on an energy equivalent basis. In comparison, based on analysis work completed at NREL, the predicted plant gate prices for ethanol produced via the thermochemical and biochemical pathways are \$1.57 per gallon (\$0.41 per liter) and \$1.49 per gallon (\$0.39 per liter), respectively (OBP 2009). Note that the PGP is for the base case. A sensitivity analysis is included in the report to demonstrate the impact that modifications in the design and costing assumptions have on the PGP. A range of PGP values is to be expected due to uncertainties in capital costs, yields, and technoeconomic factors.

This report is a future look at the potential of the described biomass-to-gasoline process, based on calculations for a mature plant (also called the n^{th} plant) and 2012 technology targets as established in the Multi-Year Technical Plan of the U.S. Department of Energy (DOE) Office of the Biomass Program. In order to achieve the \$1.95/gallon (\$0.52/liter) PGP, there are critical research milestones that must be achieved. First, the 2012 tar reforming targets of 99.9% tar and 80% methane conversion (among others) are essential. Also, utilization of a fluidized bed MTG reactor, instead of the commercially proven fixed bed, is pertinent in keeping capital costs down. Thus, further research on this type of reactor is needed 1) to verify that at the conditions specified the products generated match the model assumptions and 2) to analyze effects of scale-up on product distribution. It should be emphasized that the PGP for a first-of-a-kind plant will be significantly higher than the PGP for an n^{th} plant.

To predict the PGP for this study, a new technoeconomic model was developed in Aspen Plus, based on the model developed for NREL's thermochemical ethanol design report (Phillips et al. 2007). The necessary process changes were incorporated into a biomass-to-gasoline model using a methanol synthesis operation followed by conversion, upgrading, and finishing to gasoline. Results of the simulation were used to obtain mass and energy flows, which were then used to size and estimate the cost of process equipment in an Excel spreadsheet-based economic model. This report follows the approach taken in the thermochemical ethanol design case: the DOE Office of the Biomass Program's 2012 research targets were used for the gasifier and tar reformer operation (Phillips et al. 2007). The methanol and MTG processes were modeled using published results.

A discounted cash flow rate of return (DCFROR) calculation was performed to determine the PGP required to meet a 10% internal rate of return (IRR). A thermal basis approach was used to account for co-products (LPG and electricity). Instead of assigning a market value to co-products and then using income from the sale of those products to offset operating costs, we used total energy production to determine the PGP on a cost per energy basis (e.g., \$/MMBtu or \$/GJ) using all products in the calculation. The higher heating value of the individual products was then used to calculate the volumetric cost of the fuels and the per-kilowatt-hour cost of electricity. This approach allocates a proportional fraction of the capital and operating costs for the plant to each of the main products.

The overall plant efficiency was 42.6% (lower heating value [LHV] basis) and the carbon efficiency to LPG and gasoline was 31%. The efficiency to the desired gasoline product was 37.7% LHV and 28% carbon efficiency. The gasifier efficiency was 74.9%. Potential process improvements include utilizing more of the tail gases to make products other than heat and electricity. Because all of the power for the plant ultimately comes from the biomass fed to the plant, any energy efficiency improvements to the plant should improve product yields.

Table of Contents

Executive Summary	iii
Table of Contents	v
List of Figures	vi
List of Tables	vi
1 Introduction	1
1.1 Background.....	2
1.2 Methanol and Methanol-to-Gasoline (MTG) Technology Discussion.....	4
1.3 Gasoline Discussion.....	9
1.4 Analysis Approach.....	10
1.5 Process Design Overview.....	13
1.6 Feedstock and Plant Size.....	15
2 Process Description	16
2.1 Feed Handling & Preparation – Area 100.....	17
2.2 Gasification – Area 200.....	18
2.3 Gas Cleanup & Conditioning – Area 300.....	19
2.4 Methanol Synthesis – Area 400.....	22
2.5 Methanol Conditioning – Area 500.....	23
2.6 Methanol to Gasoline Conversion (MTG) – Area 1400.....	24
2.7 Gasoline Separation – Area 1500.....	25
2.8 Steam System and Power Generation – Area 600.....	27
2.9 Cooling Water and Other Utilities – Area 700.....	29
2.10 Additional Design Information.....	31
2.11 Thermal and Pinch Analyses.....	31
2.12 Water Demands.....	32
3 Process Economics	33
4 Economics - Results	38
4.1 Cost Contribution for Gasoline.....	39
4.2 Sensitivity Analyses.....	40
5 Conclusions	43
6 Acknowledgments	44
7 References	45
Appendix A. List of Acronyms	50
Appendix B. Comparison of Aspen Model to Four MTG Compositions from Literature	51
Appendix C. NREL Biorefinery Design Database Description and Summary	54
Appendix D. Individual Equipment Cost Summary	61
Appendix E. Economic Summary Page from Excel Spreadsheet	70
Appendix F. Discounted Cash Flow Rate of Return Summary	71
Appendix G. Heat Exchanger Network	75
Appendix H. Process Flow Diagrams	78
Appendix I. Comparison to other Biomass-to-Gasoline and Methanol-to-Gasoline Published Costs	101
I.1 Comparison to “Techno-economic Analysis for the Conversion of Lignocellulosic Biomass to Gasoline via the Methanol-to-Gasoline (MTG) Process” by S. B. Jones and Y. Zhu from Pacific Northwest National Laboratory (PNNL).....	101
I.2 Comparison of Total Project Investment to Published Cost Information from the New Zealand MTG Commercial Plant (Seddon 2006).....	102
Appendix J. External Reviewer Comments and Responses	103

List of Figures

Figure 1. Process schematic of the crude gasoline separations area.....	8
Figure 2. Approach to process analysis	10
Figure 3. <i>Chemical Engineering</i> Magazine's Plant Cost Indices.....	13
Figure 4. Block flow diagram.....	13
Figure 5. Current case design block flow diagram of thermochemical gasoline from biomass-derived methanol and the methanol-to-gasoline process.....	17
Figure 6. Composition of conventional gasoline wt % (typical)	27
Figure 7. Pinch analysis composite curves	32
Figure 8. Cost breakdown by area in \$/gallon	40
Figure 9. Sensitivity analysis for biomass-to-gasoline process	43

List of Tables

Table 1. Gasifier and Tar Reformer Performance Targets in 2012	3
Table 2. Fluidized Bed Reactor Pressure (P1000) Effects on LPG Yields and PGP.....	5
Table 3. Fixed Bed Reactor Conditions for the Methanol to Gasoline Processes	6
Table 4. Gasoline Regulations from Before the Clean Air Act of 1990, as a Result of the Clean Air Act of 1990, and California Regulations for Reformulated Gasoline.....	9
Table 5. <i>Chemical Engineering</i> Magazine's Plant Cost Indices	12
Table 6. Ultimate Analysis of Hybrid Poplar Feed.....	16
Table 7. Gasifier Operating Parameters, Gas Compositions, and Efficiencies	19
Table 8. Current and Target Design Performance of Tar Reformer	20
Table 9. Tar Reformer Conditions and Outlet Gas Composition	20
Table 10. Acid Gas Removal Design Parameters.....	21
Table 11. Process Conditions for Methanol Synthesis	23
Table 12. Composition of Crude Methanol Intermediate in Model.....	24
Table 13. MTG Reaction Conditions and Yields.....	25
Table 14. Composition of LPG from Aspen Model	27
Table 15. Power Requirements for Plant by Process Area	29
Table 16. Utility and Miscellaneous Design Information.....	31
Table 17. Process Water Demands	33
Table 18. Installed Equipment Costs by Process Area	34
Table 19. General Cost Factors in Determining Total Installed Equipment Costs.....	34
Table 20. Cost Factors for Indirect Costs	34
Table 21. Breakdown of Operating Cost Contribution to PGP	35
Table 22. Variable Operating Costs.....	36
Table 23. Economic Parameters	37
Table 24. Labor Costs.....	38
Table 25. Other Fixed Costs	38
Table 26. Process and Economic Results Summary for 2012 BTG Case	39
Table 27. List of Variables for Sensitivity Analyses	41
Table I-1. Comparison of NREL and PNNL Model Assumptions and Effect on PGP	101

1 Introduction

In his 2006 State of the Union Address, President Bush declared that America is “addicted to oil” and announced the Advanced Energy Initiative (AEI), which included increased research funding for cutting edge biofuels production processes. In response to the AEI, Congress passed a Renewable Fuel Standard (RFS) as part of the Energy Independence and Security Act (EISA) of 2007 that requires 36 billion gallons (136.3 billion liters) of biofuels per year by 2022 (Biomass Research and Development Board 2008). In February 2010, President Obama and the U.S. Environmental Protection Agency (EPA) announced a finalized Renewable Fuel Standard 2.0 (RFS2) to implement the long-term RFS (Biomass Intel 2010). In reference to the RFS, U.S. Department of Energy (DOE) Secretary Chu stated, “Developing the next generation of biofuels is key to our effort to end our dependence on foreign oil and address the climate crisis...” (The White House 2009).

The current analysis was conducted to investigate one of several possible biofuels that can be produced using the thermochemical route of gasification and synthesis. The basis for this study was a stand-alone gasification/synthesis process including sub-processes or unit operations for integrated tar reforming, acid gas scrubbing, and synthesis to methanol followed by conversion to gasoline. This biomass-to-gasoline process will be referred to as the BTG process in this report.

The starting point for this study was the model developed for the National Renewable Energy Laboratory’s (NREL’s) 2007 thermochemical ethanol design report (EDR) (Phillips et al. 2007). The report was based on achieving research targets in key barrier areas for cellulosic ethanol. That study concluded that, within the typical uncertainties inherent to this type of conceptual technoeconomic analysis, ethanol could be produced at a Minimum Ethanol Selling Price (MESP) of \$1.01 per gallon (\$0.27 per liter) in 2005 U.S. dollars based on a feedstock cost of \$35 per dry U.S. ton (\$38.60 per dry metric tonne). The DOE Office of the Biomass Program (OBP) Multi-Year Program Plan (MYPP) updated the MESP to \$1.57 per gallon (\$0.41 per liter) in 2007 U.S. dollars with a feedstock cost of \$50.70 per dry U.S. ton (\$55.89 per dry metric tonne) and with adjusted alcohol synthesis targets. As published in the EDR, the yield was 80.1 gallons of fuel grade ethanol per U.S. ton of dry biomass (334.2 liters of ethanol per metric tonne of dry biomass). As published in the OBP MYPP, the ethanol yield is 71.1 gallons of ethanol per dry U.S. ton of biomass (296.7 liters of ethanol per dry metric tonne of biomass) because of adjusted alcohol synthesis targets (OBP 2009).

The feedstock for the EDR was poplar wood with 50% moisture. The same feedstock is used here. Prior to being fed into the gasifier, the feedstock is dried to a moisture level between 5 wt % and 20 wt %, depending on the amount of waste heat available for drying. In the EDR, the wood moisture level was 5 wt % at the dryer outlet. In this study, the process conditions dictated a higher moisture level (10 wt %) because insufficient waste heat was available to achieve the same level of dryness as in the EDR. The gasifier efficiency was reduced due to this higher moisture content in the feed, which slightly affected the “raw” syngas composition.

The front end of the thermochemical process is similar in both the production of ethanol (EDR) and the production of gasoline (via BTG). Because a new slate of products is being formed in the BTG case, thus using different catalytic processes, the overall process heat integration and

materials requirements are modified. So, although the front-end process equipment is similar in both cases, the process flows and equipment sizes are significantly different between the two processes. In both studies, the best use of process and heat streams was attempted to achieve optimum productivity and economics. The complexity of the thermochemical processes makes it difficult to determine whether the best economic scenarios have been found. It is likely, especially in the BTG case, that better scenarios can be developed for achieving higher gasoline yields and lower production costs.

1.1 Background

Prior to the publication of the EDR in 2007, a 2005 milestone report (Aden et al. 2005) reviewed the history of thermochemical techno-economic studies at NREL. Sections of that report, as well as some of the EDR, are repeated here for convenience and updated with work completed since those reports were published.

An extensive literature search on mixed alcohols research and technology was included in the 2005 milestone report (Aden et al. 2005). A technical evaluation firm was subcontracted to document the current state of mixed alcohols technology for NREL (Nexant 2006a-d). Several conceptual process designs and models were developed to generate detailed mass and energy balance data. NREL's previous thermochemical design report (Spath et al. 2005) served as the basis for the feed preparation, drying and handling, gasification, gas cleanup and conditioning, and compression sections for the process model. For the EDR, ethanol was obtained by mixed alcohol synthesis, separation, and purification, and the appropriate sections were added to the model. The mass and energy balance data were used within a discounted cash flow rate of return economic analysis (DCFROR), along with capital and operating costs, to calculate the minimum product selling price required to meet a 10% internal rate of return (IRR). Sensitivity analyses were conducted around several parameters to determine the extent of their impact on the overall economics of the process.

In 2006, the thermochemical models from previous studies were reviewed and updated. The detailed EDR (Phillips et al. 2007) was published in January 2007. One of the new elements of that report was that it looked only at the techno-economic results for the year 2012 using the target performance goals established in the DOE OBP Multi-Year Technical Plan (OBP 2008). A second update was that the operating parameters that are the subject of OBP research targets were estimated for 2012. (The present BTG study uses the same values for these parameters, as shown in Table 1.) Third, in addition to the tar reformer targets used in the previous studies, which were kept unchanged, anticipated improvements in the mixed alcohol catalyst were incorporated into the EDR study. The sensitivity to the target parameters was shown along with other non-research parameters used in the study such as feedstock moisture and cost.

Table 1. Gasifier and Tar Reformer Performance Targets in 2012

Compound	2012 Targets for Tar and Methane Conversion Reforming
Methane (CH ₄)	80%
Ethane (C ₂ H ₆)	99%
Ethylene (C ₂ H ₄)	90%
Tars (C ₁₀₊)	99.9%
Benzene (C ₆ H ₆)	99%
Ammonia (NH ₃) ^a	90%

^a Converts to N₂ and H₂

A lack of published data on mixed alcohol catalysts – and non-existent published data on commercial mixed alcohol catalysts – significantly increased the uncertainty of the EDR results, because some potential performance parameters had to be deduced from other similar catalyst systems with published results (e.g., Fischer-Tropsch and methanol catalysts). The key result of the EDR was that fuel ethanol could be produced from biomass via gasification and mixed alcohols synthesis for \$1.01 per gallon (\$0.27 per liter) (based on a feedstock cost of \$35 per U.S. ton [\$38.60 per metric tonne] and in 2005 dollars), a price slightly below the cost target defined in 2005 (\$1.07 per gallon ethanol [\$0.28 per liter ethanol]).

Based on the EDR, it became possible to address questions on different technologies and fuels using a common base model and common assumptions, where meaningful. The first derivative of the EDR was a report which looked at a different gasifier design (Dutta and Phillips 2008). The EDR used an indirectly heated steam gasifier operating at near-atmospheric pressure. Dutta and Phillips incorporated many of the features of the EDR model into a new model using an oxygen-blown, medium-pressure gasifier to produce syngas that was later converted into ethanol. New equipment, such as an air separation unit (ASU), was added to the design and economic evaluation. That study showed that the alternate gasifier design would not achieve the \$1.07 per gallon (\$0.28 per liter) minimum cost target for ethanol. The additional cost of the ASU and lower methane conversions in the reformer under higher operating pressures were major contributors to the higher MESP of \$1.57 per gallon (\$0.41 per liter) (using the 2005 cost assumptions, thus comparing with \$1.01 per gallon [\$0.27 per liter] ethanol via the indirect gasification process).

Besides ethanol, investigated in the EDR, many other fuels have been investigated over the past 30 years. Those include methanol, Fischer-Tropsch liquids (FTL), and gasoline from the methanol-to-gasoline (MTG) process (Bartholomew and Farrauto 2006). All of these investigations used processes producing fuels on a large scale using syngas derived from abundant sources, such as coal and natural gas. In the latter case, excess or stranded natural gas was converted into methanol, allowing the gas to be made transportable to end users. As a result, in all areas of the world except for China, methanol is produced almost entirely from natural gas reforming (steam methane reforming) (Haddeland 1981). FTL has been used successfully in South Africa for more than 50 years to provide gasoline to that country. There, syngas produced

via coal gasification is fed to catalytic reactors, which were initially developed by several companies; however, Sasol's proprietary technology in this field became dominant later.

In the late 1970s, Mobil Oil (now part of ExxonMobil) developed the MTG process to convert natural gas via methanol into gasoline (Schreiner 1978). The gasoline was called M-gasoline. A technically successful demonstration plant was operated in New Zealand for several years before being dismantled because of the inability to compete against lower priced petroleum-derived gasoline. More recently, in 2007 DKRW Advanced Fuels began work to create a coal-to-gasoline plant using ExxonMobil's MTG process. The plant is located in Carbon County, Wyoming, and is predicted to come online in 2013 with an initial production capacity of 15,000–20,000 barrels (630,000–840,000 gallons or 2.4 million–3.2 million liters) per day (DKRW Advanced Fuels 2007). Also in 2008, Synthesis Energy Systems announced its agreement with ExxonMobil for up to 15 methanol-to-gasoline licensed plants in their global operations, the first of which would produce 7,000 barrels (294,000 gallons or 1.1 million liters) per day and be located near Benwood, West Virginia (BusinessWire 2008). Due to the economic downturn in 2008, the latter plant could not be financed. Though not modeled here, another method, TIGAS, has been developed from the MTG technology to produce gasoline from synthesis gas in a single-loop process, thus eliminating the need for methanol production and storage (Haldor Topsoe 2010).

A natural extension of the aforementioned ethanol fuel studies is to combine the biomass-to-syngas technologies from the EDR with the other existing syngas conversion technologies developed over nearly 80 years of research. The purpose of this report is to provide one such analysis: the BTG process.

Perhaps the main advantage of the biomass-to-gasoline process is that it produces a “drop-in fuel,” i.e., a fuel that can be accommodated in the current motor-fuel infrastructure without any adaptations to it. It should also have lower risks for investors than processes with less developed technologies, because the methanol synthesis process is well developed and commercial. The MTG process has commercial experience, with proven performance using conditioned syngas, especially when using the fixed bed MTG reactors. The risk in the front end of the process, upstream from the synthesis reactor(s), is the same for both the thermochemical ethanol and gasoline processes because they are essentially identical.

At the plant gate, the point at which this evaluation ends, the potential benefit to a gasoline product is that it can be shipped long distances using the interstate pipeline system already in place with few, if any, restrictions. The fuel is fungible with the existing fuel distribution infrastructure, although it may need to be blended with more conventional gasoline products to meet current fuel specifications.

1.2 Methanol and Methanol-to-Gasoline (MTG) Technology Discussion

A plethora of published literature exists for syngas conversion to methanol, with bibliographies available in books by Lee (Lee 1990) and Bartholomew (Bartholomew and Farrauto 2006). The first-generation methanol synthesis catalyst, developed by BASF in 1923, required a temperature of 300°C–400°C and pressure of up to 30 MPa. Since that time, the required pressure (4–100 MPa) and temperature (180°C–250°C) have decreased. A commercial methanol synthesis catalyst today can have selectivity to methanol as high as 99.9% and yields of up to 2.28 kg of

methanol per liter of catalyst per hour. Because the methanol catalysts are commercially available, the synthesis reaction should typically perform as presented in the literature. No discussion of methanol reaction mechanisms or other highly technical information is given here. Interested readers are referred to the references used above.

In contrast to the abundant literature for methanol synthesis, there is a dearth of published literature for the methanol-to-gasoline (MTG) process. The MTG process was developed by Mobil (now part of ExxonMobil) in the late 1970s. A DOE report from 1978 assessing gasoline production from coal using MTG and Sasol-type Fischer-Tropsch technologies provided much of the information used in the present study (Schreiner 1978). The DOE study was done in part by researchers from Mobil Research and Development Corporation. Several references (Probstein and Hicks 1982; Edwards and Avidan 1986; Chang 1992; Gary and Handwerk 1994; Mokrani and Scurrall 2009) also provided limited insight to the operating conditions, product distributions, and process equipment needs.

The 1978 DOE report is one of the earliest published studies on the MTG process. It was based on a Lurgi high-pressure coal gasifier to generate syngas and the Lurgi methanol synthesis process to make methanol for the MTG process. The MTG data used in the report came from a jointly funded process development study, using fixed bed reactors, between Mobil and DOE under contract E (49-18)-1773 (Schreiner 1978).

In the MTG process the methanol, or rather its dehydrated derivative dimethylether (DME), is reacted over a ZSM-5 zeolite catalyst, on which the chain growth of molecules is sterically hindered, thus allowing only production of gasoline and lighter material. This report evaluates the MTG process for a fluidized bed reactor, in which case direct conversion is possible, because both the conversion of methanol to DME as well as the synthesis of DME to gasoline can be performed in one reactor. The fluidized bed reactor has been technically proven at the demonstration plant in Germany (100–200 bpd [4,200–8,400 gal/day; 15,900–31,800 L/day]). The running conditions for a typical fluidized bed MTG reactor are 400°C and 60 psi (413 kPa) (Probstein and Hicks 1982; Gayubo et al. 1999). However, in this study the MTG reactor pressure is 200 psi (1.38 MPa). The higher pressure improved LPG recovery and yields in the model. Table 2 shows the LPG yields and PGP as a function of MTG reactor pressure. These changes in LPG yields do not include possible product composition changes with respect to pressure.

Table 2. Fluidized Bed Reactor Pressure (P1000) Effects on LPG Yields and PGP

P1000 Pressure		PGP		LPG Yield	
(psig)	(MPa)	(\$/gallon)	(\$/liter)	(lb/h)	(kg/h)
200	1.38	\$1.95	\$0.515	3,659	1,663
150	1.04	\$1.96	\$0.518	3,426	1,557
100	0.69	\$1.98	\$0.523	2,982	1,355
90	0.62	\$2.00	\$0.528	2,791	1,269
60	0.41	\$2.17	\$0.573	1,354	615

The fluid bed scale-up to pilot scale from bench scale (100–200 bpd [4,200-8,400 gal/day; 15,900-31,800 L/day] from 4 bpd [168 gal/day; 636 L/day]) was reported to have been achieved

without loss of conversion efficiency while the heat management, steady activity level, higher gasoline yield, and octane number were retained. The successful scale-up is attributed to attention to Peclet number, a superficial velocity greater than 0.3 m/s, and turbulent flow through the reactor. The demonstration plant in Germany was reported to have conversion efficiencies greater than 99.9% (Edwards and Avidan 1986).

However, if a fixed bed reactor is desired, the conversion process will need to take place in two steps. The first step is to pass the methanol over a methanol dehydration catalyst to form a mixture of methanol, DME, and water, and the second step is converting this mixture to gasoline over the ZSM-5 zeolite catalyst. In the 1977 report, a large gas recycle was used to limit the temperature rise across the ZSM-5 fixed catalyst bed to 125°F (52°C). The ZSM-5 zeolite catalyst is known to deactivate via coke formation over a period of about two weeks. In the fixed bed case, five parallel reactors are used to convert the DME/methanol mixture, with one reactor being taken offline every two weeks for regeneration with air to remove the coke. In the fluidized bed reactor, the catalyst is continuously withdrawn and regenerated by partially burning off the coke (Mokrani and Scurrrell 2009).

Typical reactor conditions for each of the two fixed bed conversion steps are given in Table 3 (Schreiner 1978).

Table 3. Fixed Bed Reactor Conditions for the Methanol to Gasoline Processes

Reactor Conditions (Schreiner)	
First Reactor (Methanol to DME)	
Pressure, inlet	401 psig (2.77 MPa)
Temperature, inlet	680°F (360°C)
Temperature, outlet	788°F (420°C)
Space velocity	6 lb fresh feed/h/lb catalyst
Estimated catalyst life	2 years
Second Reactor (DME to Gasoline)	
Pressure, inlet	200 psig (1.38 MPa)
Temperature, inlet	625°F (330°C)
Temperature, outlet	752°F (400°C)
Space velocity	1.84 lb fresh feed/h/lb catalyst
Estimated catalyst life	1 year

The MTG process dehydrates methanol to DME and subsequently synthesizes DME to gasoline hydrocarbons and LPG with stoichiometric yields to hydrocarbons and water of 44% and 56%, respectively (Schreiner 1978). According to the 1978 DOE report, “The gasoline is chemically conventional consisting of highly branched paraffins (51%), highly branched olefins (13%), naphthenes (8%), and aromatics (28%).” Amongst the latter, one less desirable product, 1,2,4,5-tetramethylbenzene (durene) is formed. An aromatics content of 28% is high, but the gasoline is envisioned to be added to a very large gasoline stream with low aromatic content. The gasoline yields modeled in this report are based upon the results published in the 1978 DOE report. However, because the large recycle of light hydrocarbons necessary for the fixed bed case is not necessary in the fluidized bed scenario, the gasoline product spectrum will contain more light

olefins and fewer light paraffins (Mokrani and Scurrall 2009). MTG gasoline is also reported to have a Research Octane Number (RON) between 90 and 100, with no products created with a carbon number greater than 10 and no oxygenates (Schreiner 1978).

Gasoline fuel specifications have changed significantly since 1978, in part because of the Clean Air Act of 1990 (as amended). Of particular issue are 1) the low benzene concentration (< 1.0 vol %) allowed in today's fuel and 2) the lower Reid Vapor Pressure (RVP) required in most parts of the country (7.0–7.8 psi [48–54 kPa] vs. 10 psi [69 kPa] in 1978). Lower RVP requirements are met today, in part, by removing most of the butanes and butenes from the gasoline. The gasoline composition will be discussed further in Section 2.2.

The hydrocarbon product from the MTG process has more than 51 compounds, similar to straight-run gasoline in a petroleum refinery. The 51 compounds reportedly made in the MTG process (Schreiner 1978) are listed in Appendix B along with product compositions from two other literature sources. The several sources agree on the composition for most of the compounds. The compositions are given in varying degrees of detail with different methods used to lump groups of compounds.

The process for upgrading of the gasoline mixture is similar to the process used in a gasoline refinery. The design used in this study came from the New Zealand MTG demonstration process design with a few minor modifications. Figure 1 shows the process schematic for the crude gasoline separations area.

The first separation step is to remove ethane from the “crude” gasoline stream using a distillation column known as a de-ethanizer. The “de-ethanized” gasoline from the bottom of the column goes to a second column known as a stabilizer that removes the lighter components, propanes and propenes (3-carbon hydrocarbons referred to as C3s), and most of the butanes and butenes. These light components are also known in the industry as liquefied petroleum gas (LPG), which can be sold or further processed to increase the gasoline yield as discussed below.

The amount of butanes and other light hydrocarbons is limited in gasoline because of RVP restrictions. To increase the gasoline yield, while utilizing the butanes and other lighter hydrocarbons, refineries typically use an alkylation unit. Alkylation is a process that joins a hydrocarbon containing a tertiary carbon (a carbon attached to three other carbons) with an olefin to create a larger branched molecule from the two smaller molecules. Of particular interest is the reaction of isobutane with 2-butene to form isooctane. If instead of 2-butene, 1-butene is reacted with isobutane, 2-methylheptane is formed. The MTG gasoline compositions given in Schreiner 1978 and in Liederman 1978 do not distinguish between 1- and 2-butene but lump them as “butenes.” Thus specific yields of 1-butene and 2-butene are unknown. The Aspen simulation is set for the alkylation unit to produce isooctane from isobutane and 2-butene. If the product is primarily 1-butene, possible reconfiguration to include an isomerization unit would shift the product yield to include greater 2-butene levels.

The addition of the hydrofluoric acid (HF) alkylation unit improves the utilization of C4 hydrocarbons while making a higher octane product, isooctane. Other alkylation products are possible using pentene and an isoparaffin, but typically these are not upgraded because they are suitable to the gasoline product as is and would require additional distillation. C3 hydrocarbons

can also be upgraded to larger molecules in the gasoline range. Because the alkylation step requires an isoparaffin to react with an olefin, additional steps, like isomerization, can be used to convert n-butane (straight-chained) to the iso form, which can then be reacted with olefins. The most common commercial alkylation processes are catalyzed by a strong acid, either hydrofluoric acid or sulfuric acid. While environmental and safety concerns with respect to the use of strong acid catalysts have prompted development of solid acid catalyst methods for alkylation units, only traditional alkylation units are considered in this study due to performance and cost data availability (Hutson 1977).

The unreacted C3 and C4 hydrocarbons from the alkylation unit are either separated from the heavier gasoline products in another column and sent to a storage tank for sale as LPG or returned to the stabilizer column where the alkylate joins the gasoline stream. If a separate column is used to separate the C3 and C4 hydrocarbons, then the alkylate is sent to a tank for storage and later blended with the other gasoline fractions.

The bottoms product from the stabilizer is sent to a splitter column to separate the stabilized gasoline into light and heavy fractions. The light fraction exits the top of the column where it is condensed and sent to a storage tank. The heavy fraction could be sent to an isomerization reactor to convert 1,2,4,5-tetramethylbenzene (durene) into 1,2,3,5-tetramethylbenzene. The former product (durene) has a relatively high freezing point (77°F, 25°C) and will crystallize in fuel systems if the concentration exceeds about 5 vol %. The isomer product has a lower freezing point. This study concluded that the isomerization reactor was unnecessary because of the dilution effect of adding the BTG gasoline to a very large conventional gasoline stream.

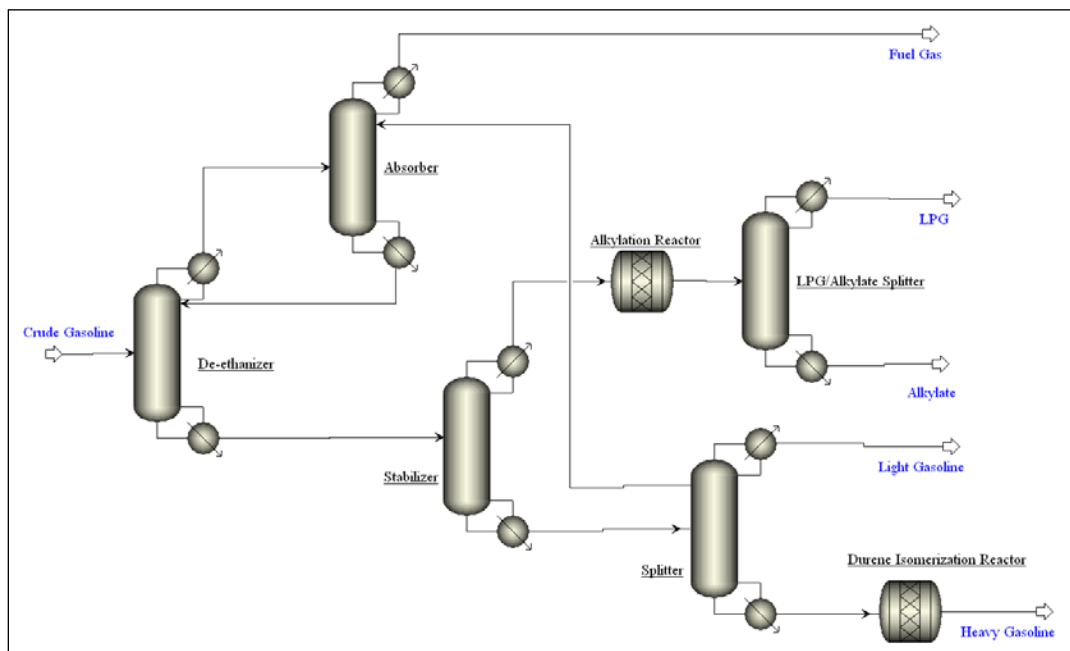

Figure 1. Process schematic of the crude gasoline separations area

1.3 Gasoline Discussion

In 1990, the Clean Air Act mandated the seasonal use of oxygenated compounds in gasoline in specific regions of the United States. According to a Government Accountability Office (GAO) report (June 2005), in 2005 there were approximately 45 different gasoline blends in use across the United States. The large number of products was due, in part, to the approaches taken to improve air quality throughout the country. Each state can voluntarily pass laws specifying the gasoline blends that must be used to meet air quality standards, and many states have done so. The EPA has required some states to use reformulated gasoline blends to meet air quality standards in cases where those standards have not been met. Each state can propose the method and fuels it wants to use to meet the air quality standards. The EPA must approve any gasoline formulation proposed by the states that meets the criteria for achieving the improved air quality specifications.

Table 4. Gasoline Regulations from Before the Clean Air Act of 1990, as a Result of the Clean Air Act of 1990, and California Regulations for Reformulated Gasoline

	Pre-1990	1990 Clean Air Act	California Air Resources Board
Benzene	2%	1% max	1.0 vol % max
Oxygen	0.20%	2% min	1.8–2.0 mass %
Sulfur	150 ppm	150 ppm max	40 ppm
Aromatics	32.00%	25% max	25 vol % max
Olefins	9.90%	5% max	6 vol % max
RVP	8.7 psi (60 kPa)	7.3/8.1 psi (50/56 kPa) (south/north)	7.0 psi (48 kPa)
90% evap.	170°C	NA	149°C

Table 4 lists key characteristics for reformulated gasolines. Two characteristics are typically specified for improving the ozone-producing potential of gasoline: the RVP and the oxygenate content. Decreased vapor pressure specifications required refiners to remove the more volatile compounds, mainly butanes and butenes, from gasoline. The maximum amount of n-butane is added to the final gasoline product while still meeting the RVP limit, which varies by season and local temperatures. The use of oxygenates was implemented to improve the gasoline combustion in car engines and to decrease the amount of unburned hydrocarbons, carbon monoxide, and nitrous oxides emitted from the tailpipe. The oxygenate requirement is typically met by “splash blending” ethanol into gasoline being loaded into tanker trucks for delivery to filling stations. Gasoline that will have oxygenate added at the terminal must be blended at the refinery gate to account for any changes in RVP and octane ratings.

With the various combinations of oxygenates and RVP requirements, multiplied by the consumer desire for three octane products to be available at each filling station, the number of products that must be managed in the gasoline distribution infrastructure has proliferated. It is possible that the gasoline product from an MTG process will be sent to an existing petroleum refinery via pipeline, blended into the refinery’s standard gasoline products, and then shipped again via pipeline or truck to the final blending stations where additives and oxygenates (ethanol) are splash blended before final distribution to filling stations. It is also possible that the MTG fuel could be sent to distributors and blended with conventional gasoline to meet final product

specifications before being sent on to filling stations, but that would require an additional storage tank for the MTG product and a new methodology for blending gasoline at a location other than the refinery.

1.4 Analysis Approach

The general approach used in the development of the process design, process model, and economic analysis is depicted in Figure 2 and described below (previously described in Phillips et al. 2007). The first step was to assemble a general process flow schematic and more detailed process flow diagrams (PFDs). (See Appendix H for the associated PFDs for this design.) From this, detailed mass and energy balance calculations were performed around the process using Aspen Plus software. Data from the Aspen model were then used to properly size all process equipment and fully develop an estimate of capital and operating costs. These costs could potentially be used in several types of economic analyses. For this design, a discounted cash flow rate of return (DCFROR) analysis was used to determine the Plant Gate Price (PGP) necessary to meet a small economic profitability or internal rate of return (IRR) of 10%.

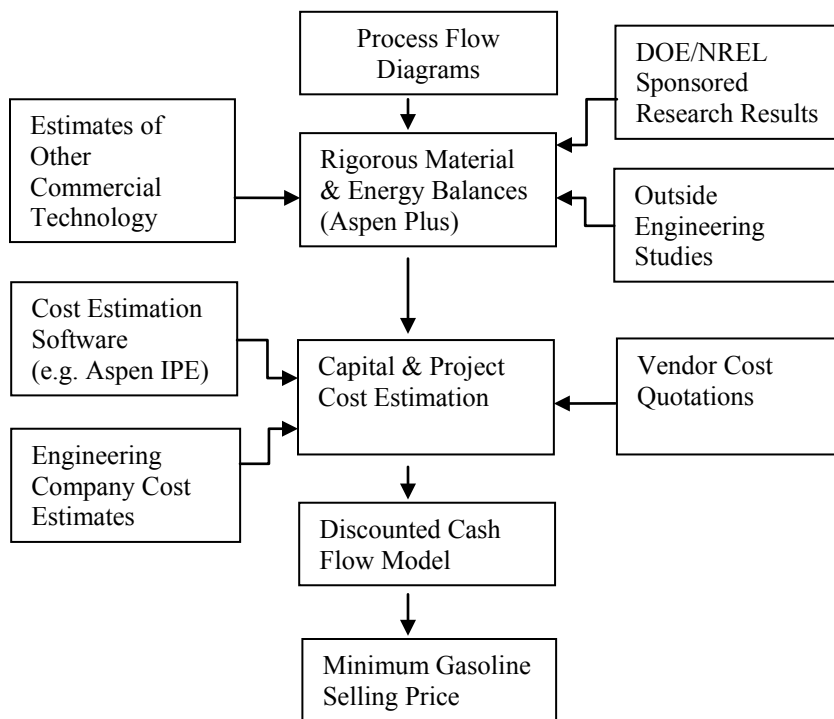

Figure 2. Approach to process analysis

This thermochemical conversion process was developed based upon in-house experience performing conceptual designs for biomass conversion to ethanol via biochemical means (Aden et al. 2002), biopower applications, and biomass gasification for hydrogen production (Spath et al. 2005). Specific information for potential sub-processes was obtained through a subcontract with Nexant Inc. (Nexant 2006a-d).

Aspen Plus version 2004.1 was used to determine the mass and energy balances for the process. The operations were separated into nine major HIERARCHY areas (the numbering gap between Areas 700 and 1400 is there to keep consistency with past reports; Areas 800 through 1300 were entirely different sections not applicable to this process):

- Feed Handling and Drying (Area 100)
- Gasification (Area 200)
- Cleanup and Conditioning (Area 300)
- Methanol Synthesis (Area 400)
- Methanol Conditioning (Area 500)
- Steam Cycle (Area 600)
- Cooling Water (Area 700)
- Methanol-to-Gasoline (Area 1400)
- Gasoline Separation (Area 1500)

Overall, the Aspen Plus simulation consists of about 400 operation blocks (such as reactors and flash separators), 1,070 streams (720 mass-, 265 heat-, and 85 work-streams), and 80 control blocks (design specifications and calculator blocks). Many of the gaseous and liquid components were described as distinct molecular species using Aspen's component properties database. The raw biomass feedstock, ash, and char components were modeled as non-conventional components. There was more detail and rigor in some blocks (e.g., distillation columns) than others (e.g., conversion extent in the methanol synthesis reactor). Because this design processes three phases of matter (solids, gases, and liquids), no single thermodynamics package was sufficient. Instead, multiple thermodynamics packages were used in the Aspen simulation as needed to model the various process streams and unit operations. The RKS-BM option was used throughout much of the process for high temperature, high pressure phase behavior. The Aspen default steam tables, STEAM-TA, were used for the steam cycle calculations, and the ELECNRTL package was used to model the electrolyte species potentially present within the quench water system.

The process economics are based on the assumption that this is the "nth" plant, meaning that several plants using this same technology will have already been built and are operating. This means that additional costs for risk financing, longer start-ups, and other costs associated with first-of-a-kind plants are not included.

The capital costs were developed from a variety of sources. For some sub-processes that are well known technologies and can be purchased as modular packages (i.e., amine treatment, acid gas removal), an overall cost for the package unit was used. Many of the common equipment items (tanks, pumps, simple heat exchangers) were costed using the Aspen Icarus Process Evaluator and Aspen Questimate costing software. For other more specific unit operations (gasifier, LOCAT system), cost estimates from other studies and/or from vendor quotes were used. As documented in the hydrogen design report (Spath et al. 2005), the installed capital costs were developed using general plant-wide factors. The installation costs incorporated cost contributions not only for the actual installation of the purchased equipment but also for instrumentation and controls, piping, electrical systems, buildings, yard improvements, etc. These are also described in more detail in Section 3, and additional information is available in Appendices C and D.

The purchased component equipment costs reflect the base case for equipment size and cost year. The sizes needed in the process may actually be different than what was initially designed. Instead of re-costing in detail, an exponential scaling expression was used to adjust the base equipment costs:

$$\text{New Cost} = (\text{Base Cost}) \left(\frac{\text{New Size}}{\text{Base Size}} \right)^n$$

where n is a characteristic scaling exponent (typically in the range of 0.6 to 0.7). The sizing parameters are based upon some characteristic of the equipment related to production capacity, such as inlet flow or heat duty in a heat exchanger (appropriate if the log-mean temperature difference is fairly similar). Generally these related characteristics are easier to calculate and give nearly the same result as resizing the equipment for each scenario. The scaling exponent n can be inferred from vendor quotes (if multiple quotes are given for different sizes), multiple estimates from IPE or Questimate at different sizes, or a standard reference (such as Garrett 1989; Peters and Timmerhaus 2003; or Perry et al. 1997). It is known that for very large equipment, n can rise to almost 1.0 as economies of scale almost disappear and multiplication of equipment is inevitable. For the size of the equipment used in this evaluation, however, economy of scale is realizable.

Because a variety of sources was used, the base equipment costs were derived based upon different cost years. Therefore, all capital costs were adjusted with the *Chemical Engineering* (CE) magazine's Plant Cost Index to a common basis year of 2007:

$$\text{New Cost} = (\text{Base Cost}) \left(\frac{\text{Cost Index in New Year}}{\text{Cost Index in Base Year}} \right).$$

The CE indices used in this study are listed in Table 5 and depicted in Figure 3. The indices were very nearly the same for 2000 to 2002 (essentially zero inflation) but take a fairly sharp increase after 2003 (primarily due to increased worldwide steel prices).

Table 5. *Chemical Engineering Magazine's Plant Cost Indices*

Year	Index
2000	394.1
2001	394.3
2002	395.6
2003	402.0
2004	444.2
2005	468.2
2006	499.6
2007	525.4

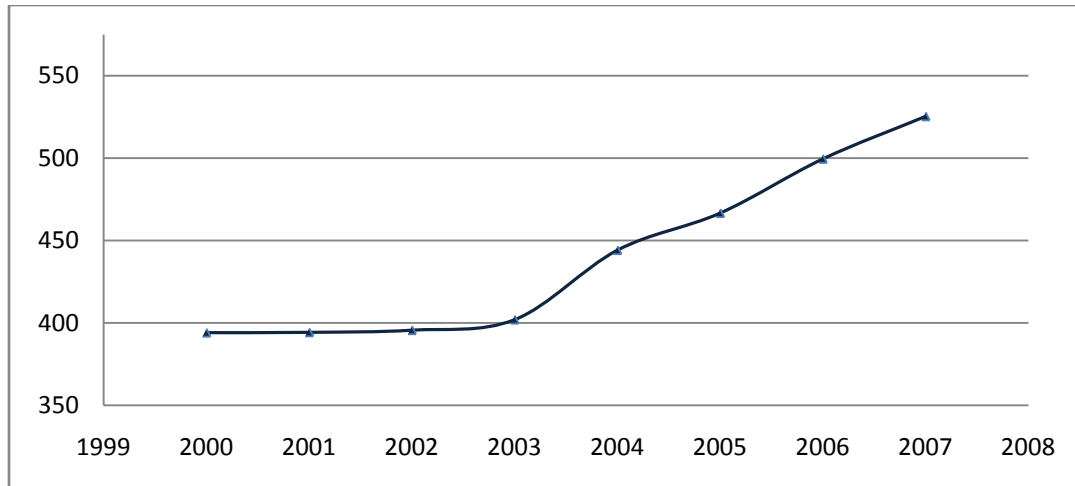

Figure 3. Chemical Engineering Magazine's Plant Cost Indices

Once the scaled, installed equipment costs were determined, we applied overhead and contingency factors to determine a total plant investment cost. That cost, along with the plant operating expenses (generally developed from the Aspen Plus model's mass and energy balance results), was used in a discounted cash flow analysis to determine the cost of gasoline production (referred to as the plant gate price or PGP). For the analysis done here, the PGP is the primary value used to compare alternate designs.

1.5 Process Design Overview

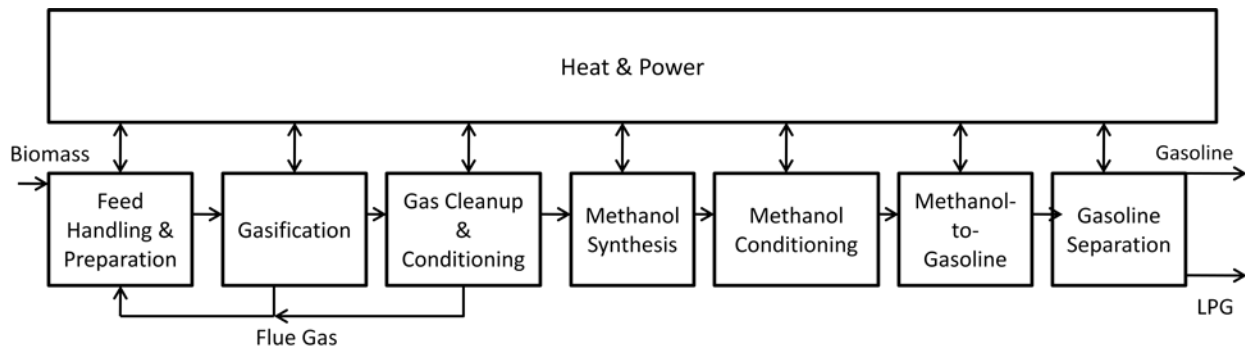

Figure 4. Block flow diagram

A simple block flow diagram of the current design is depicted in Figure 4. The detailed process flow diagrams (PFDs) are in Appendix H. The process has the following steps (the process steps up to the methanol synthesis section were previously explained in Phillips et al. [2007], with modifications made to the gas cleanup and conditioning section):

- *Feed Handling & Preparation.* The biomass feedstock (2,000 dry metric tonne/day [2,205 dry U.S. ton/day]) is dried from the as-received moisture content to that required for proper feeding into the gasifier using flue gases from the char combustor and tar

reformer catalyst regenerator. Prior to drying, wood chips with a diameter larger than 2 inches are sent to the hammer-mill for further size reduction.

- *Gasification.* Indirect gasification is considered in this assessment. Heat for the endothermic gasification reactions is supplied by circulating hot synthetic olivine¹ “sand” between the gasifier and the char combustor. Conveyors and hoppers are used to feed the biomass to the low-pressure indirectly-heated entrained flow gasifier. Steam is injected into the gasifier to aid in stabilizing the entrained flow of biomass and sand through the gasifier. The biomass is chemically converted to a mixture of syngas components (CO, H₂, CO₂, CH₄, etc.), tars, and a solid “char” that is mainly the fixed carbon residual from the biomass plus carbon (coke) deposited on the sand. Cyclones at the exit of the gasifier separate the char and sand from the syngas. These solids flow by gravity from the cyclones into the char combustor. Air is introduced to the bottom of the combustor reactor and serves as a carrier gas for the fluidized bed plus as the oxidant for burning the char and coke. The heat of combustion heats the sand to more than 1800°F (982°C). The hot sand and residual ash from the char is carried out of the combustor by the combustion gases and separated from the hot gases using another pair of cyclones. The first cyclone is designed to capture mostly sand while the smaller ash particles remain entrained in the gas exiting the cyclone. The second cyclone is designed to capture the ash and any sand passing through the first cyclone. The hot sand captured by the first cyclone flows by gravity back into the gasifier to provide the heat for the gasification reaction. Ash and sand particles captured in the second cyclone are cooled, moistened to minimize dust, and sent to a landfill for disposal.
- *Gas Cleanup & Conditioning.* This consists of multiple operations: reforming of tars and other hydrocarbons to CO and H₂; syngas cooling/quench; and acid gas (CO₂ and H₂S) removal. Tar reforming is envisioned to occur in an isothermal fluidized bed reactor; deactivated reforming catalyst is separated from the effluent syngas and regenerated online. The hot syngas is cooled through heat exchange with a steam cycle and additional cooling via water scrubbing. The scrubber also removes impurities such as particulates and ammonia along with any residual tars. The excess scrubber water is sent off-site to a wastewater treatment facility. In order to increase methanol production, a sulfur resistant low-temperature-water-gas-shift (LTS) reactor improves the syngas H₂:CO ratio after scrubbing. After leaving the LTS, the syngas enters an amine unit for removal of the CO₂ and H₂S and subsequently enters the methanol synthesis reactor. The H₂S is reduced to elemental sulfur and stockpiled for disposal. The CO₂ is vented to the atmosphere in this design.
- *Methanol Synthesis.* The cleaned and conditioned syngas is converted to methanol in a fixed bed reactor containing a copper/zinc oxide/alumina catalyst. The mixture of methanol and unconverted syngas is cooled through heat exchange with the steam cycle and other process streams. The methanol is separated by condensing it away from the unconverted syngas. Unconverted syngas is recycled back to the entrance of the methanol synthesis reactor.

¹ Calcined magnesium silicate, primarily Enstatite (MgSiO₃), Forsterite (Mg₂SiO₃), and Hematite (Fe₂O₃). This is used as a sand for various applications. A small amount of magnesium oxide (MgO) is added to the fresh olivine to prevent the formation of glass-like bed agglomerations that would result from biomass potassium interacting with the silicate compounds.

- *Methanol Conditioning.* The methanol leaving the reactor has been condensed at elevated pressure and has absorbed a sizeable quantity of gas. The methanol and gas stream is first heated and sent through a turbo expander generator to recover a portion of the compression energy. Once the stream is at a lower temperature it is sent to a distillation column to degas the methanol. This removal of gases could be done at a later stage in the process.
- *Methanol-to-Gasoline.* The methanol is then passed through a fluidized bed reactor containing the ZSM-5 zeolite catalyst. Direct conversion to gasoline is achieved in the fluidized bed reactor. The gasoline product from the MTG process has more than 51 compounds, similar to straight-run gasoline in a petroleum refinery.
- *Gasoline Separation.* The separation of the gasoline mixture is similar to the process used in a gasoline refinery. The design used in this model came from the New Zealand MTG demonstration process design with a few minor modifications, as shown in Figure 1. This design utilizes five distillation columns to separate the remaining gas, LPG, light gasoline, and heavy gasoline. The remaining gas is sent to the fuel combustor. The light gasoline continues without further treatment. And the heavy gasoline could proceed through a durene isomerizer in order to eliminate the presence of the 1,2,4,5-tetramethylbenzenes by converting them to 1,2,3,5-tetramethylbenzenes. This stream would then be merged with the light gasoline. The two product streams are LPG and gasoline.
- *Heat & Power.* A conventional steam cycle produces heat (as steam) for the gasifier and reformer operations and electricity for internal power requirements (with the possibility to export excess electricity as a co-product). The steam cycle is integrated with the biomass conversion and MTG processes. Pre-heaters, steam generators, and super-heaters are integrated within the process design to create the steam. The steam will run through turbines to drive compressors, generate electricity, or be withdrawn at various pressure levels for injection into the process. The condensate will be sent back to the steam cycle, de-gassed, and combined with makeup water.

A cooling water system is also included in the Aspen Plus model to determine the requirements of each cooling water heat exchanger within the biomass conversion process as well as the requirements of the cooling tower.

Previous analyses of gasification processes have shown the importance of properly utilizing the heat from the high temperature streams. A pinch analysis was performed to analyze the energy network of this gasoline production process. Details of the pinch analysis will be discussed in Section 3.11.

1.6 Feedstock and Plant Size

Based upon expected availability per the “Billion Ton” vision study (Perlack et al. 2005), forest resources were chosen as the primary feedstock. The “Billion Ton” study addressed short- and long-term availability issues for biomass feedstocks without giving specific time frames. In the target year of 2012, it is most likely that only the “existing” and “unexploited” resources can be counted on to supply a thermochemical processing facility. Therefore, it is logical to base thermochemical processing on the forest resources. Thermochemical processing could provide a

cost-effective technology to process this major portion of the expected biomass feedstock (Phillips et al. 2007).

The design plant size for this study—2,000 dry metric tonne/day (2,205 dry U.S. ton/day)—was chosen to match that of the biochemical process (Aden et al. 2002). For the process described here, the plant would produce just over one million barrels per year or 42.5 million gallons (160.9 million liters) per year. With an expected 8,406 operating hours per year (96% operating factor or stream factor), the annual feedstock requirement is 700,000 dry metric tonne/yr (772,000 dry U.S. ton/yr).

The delivered feedstock cost was chosen to match recent analyses done at Idaho National Laboratory to target \$50.70 per dry U.S. ton (\$55.89 per dry metric tonne) by 2012 (OBP 2009). Cost effects due to feedstock cost were also examined as part of the sensitivity analysis.

Past analyses have used hybrid poplar wood chips delivered at 50 wt % moisture to model forest resources; the same will be done here. The ultimate analysis for the feed used in this study is given in Table 6. Performance and cost effects due to composition and moisture content were examined as part of the sensitivity analysis and alternate scenarios (Phillips et al. 2007).

Table 6. Ultimate Analysis of Hybrid Poplar Feed

Component (wt %, dry basis)^a	
Carbon	50.88
Hydrogen	6.04
Nitrogen	0.17
Sulfur	0.09
Oxygen	41.90
Ash	0.92
Heating value ^b (Btu/lb)	8,671 HHV (20.1 MJ/kg) 8,060 LHV (18.7 MJ/kg)

^a Craig and Mann 1996. ^b Calculated using the Aspen Plus Boie correlation.

2 Process Description

As mentioned above, the starting point for this model was the thermochemical ethanol model used in the EDR. The synthesis reactor was changed to make predominantly methanol, and the syngas conditioning requirements (e.g., sulfur and CO₂ concentration, H₂:CO ratio) and reaction conditions (temperature, pressure, residence time) were changed to match the methanol process requirements. The post-synthesis sections of the process were a major addition to the EDR model. Although the fluidized bed MTG process design was given in other reports, there were enough differences in the current model to prevent direct use of those process parameters in this study. Specifically, since no outside energy was allowed in this design, the lightest hydrocarbons were combusted instead of proceeding to the alkylation unit. However, butanes still proceed to the alkylation unit. Distillation column operating parameters were set by using column design specifications that would give “acceptable” effluent compositions. Because gasoline does not have a specific composition but rather a range of acceptable compositions for various component groups (e.g., aromatics, olefins, paraffins) that meet overall performance criteria and physical

characteristics such as octane number and vapor pressure, an attempt to select reasonable design specifications was used.

A block-flow diagram depicting the current case design is shown in Figure 5 for a 2,000 dry metric tonne/day (2,205 dry U.S. ton/day) BTG process. The front end of the process (through steam reforming) remains substantially similar to the EDR (Phillips et al. 2007).

Process flow diagrams (PFDs) for the BTG process are available in Appendix H.

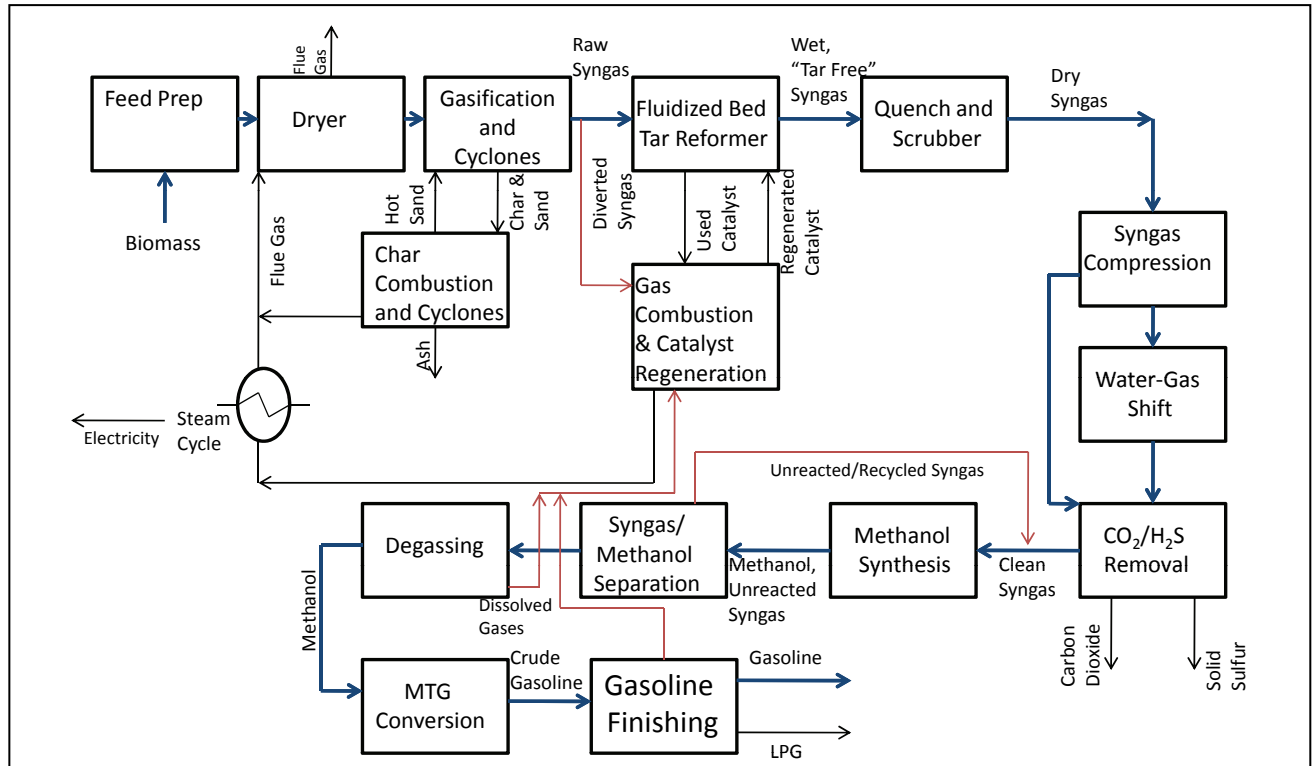

Figure 5. Current case design block flow diagram of thermochemical gasoline from biomass-derived methanol and the methanol-to-gasoline process

2.1 Feed Handling & Preparation – Area 100

This section of the process accommodates the delivery of the biomass feedstock, short-term on-site storage, and the preparation of the feedstock for the gasifier. The design is based upon a woody feedstock. It is expected that the feed handling area for agricultural residues would be very similar.

The feed handling and drying sections are shown in PFD-P850-A101 and PFD-P850-A102. Wood chips are delivered to the plant primarily via trucks; delivery by train could be an attractive alternative. As the trucks enter the plant they are weighed (M-101), and the wood chips are dumped into a storage pile. From the storage pile, the wood chips are conveyed (C-102) through a magnetic separator (S-101) and screened (S-102). Particles larger than 2 inches are sent through a hammer-mill (T-102/M-102) for further size reduction. Front end loaders transfer the wood chips to the dryer feed bins (T-103).

Drying is accomplished by direct contact of the biomass feed with hot flue gas. The 2,000 dry metric tonne/day (2,205 dry U.S. ton/day) plant requires two identical, parallel feed handling and drying trains. The wet wood chips enter each rotary biomass dryer (M-104) through a dryer feed screw conveyor (C-104). The wood is dried to a moisture content of 10 wt % with flue gas from the char combustor (R-202) and the tar reformer's fuel combustor (R-301). The exhaust gas exiting the dryer is sent through a cyclone (S-103) and baghouse filter (S-104) to remove particulates prior to being emitted to the atmosphere. The stack temperature is controlled by cooling the hot flue gas from the char combustor and the tar reformer with two steam boilers (H-286B and H-311B) prior to entering the dryer. This generated steam is added to the common steam drum (T-604) (see Section 3.8). The dried biomass is then conveyed to the gasifier train (T-104/C-105).

2.2 Gasification – Area 200

This section of the process converts a mixture of dry feedstock and steam to syngas and char (also described in Phillips et al. 2007). Heat is provided in an indirect form by circulating olivine that is heated by the combustion of the char downstream of the gasifier. The steam primarily acts as a fluidizing medium in the gasifier and also participates in certain reactions when high gasifier temperatures are reached.

From the feed handling and drying section, the dried wood enters the gasifier section as shown in PFD-P850-A201. The 2,000 dry metric tonne/day (2,205 dry U.S. ton/day) plant was modeled using two parallel gasifier trains. The gasifier (R-201) used in this analysis is a low-pressure indirectly-heated circulating fluidized bed (CFB) gasifier. The gasifier was modeled using correlations based on run data from the Battelle Columbus Laboratory (BCL) 9 metric tonne/day (9.9 U.S. ton/day) test facility (Bain 1992).

The heat for the endothermic gasification reactions is supplied by circulating a hot medium between the gasifier vessel and the char combustor (R-202); in this case the medium is synthetic olivine, a calcined magnesium silicate, primarily Enstatite (MgSiO_3), Forsterite (Mg_2SiO_3), and Hematite (Fe_2O_3). A small amount of magnesium oxide (MgO) must be added to the fresh olivine because it titrates the potassium in the feed ash. Without the MgO addition, the potassium will form glass (K_2SiO_4) with the silica in the system. K_2SiO_4 has a low melting point (approximately 930°F, 500°C), and its formation will cause the bed media to become sticky, agglomerate, and eventually defluidize. Adding MgO makes the potassium form a high melting point (approximately 2,370°F, 1,300°C) ternary eutectic with the silica, thus sequestering it. Potassium carryover in the gasifier/combustor cyclones is also significantly reduced. The ash content of the feed is assumed to contain 0.2 wt % potassium. The MgO flow rate is set at 2 times the molar flow rate of potassium.

The gasifier fluidization medium is steam supplied from the steam cycle (see Section 3.8). The steam-to-feed ratio is 0.4 lb of steam per lb of dry biomass. The gasifier pressure is 23 psia (159 kPa). The olivine circulating flow rate is 27 lb of olivine per lb of dry wood. Fresh olivine is added at a rate of 0.01% of the circulating rate to account for losses. The char combustor is operated with 20% excess air.

Both the gasifier and char combustor temperatures are dictated from the energy balances around the gasifier and combustor. The gasifier temperature is 1,622°F (883°C) and the char combustor

temperature is 1816°F (991°C). The composition of the outlet gas from the gasifier is shown in Table 7.

Table 7. Gasifier Operating Parameters, Gas Compositions, and Efficiencies

Gasifier Variable	Value	
Temperature	1,622°F (883°C)	
Pressure	23 psia (159 kPa)	
Gasifier Outlet Gas Composition	mol % (wet)	mol % (dry)
H ₂	13.9	24.7
CO ₂	7.1	12.6
CO	23.7	42.0
H ₂ O	43.6	--
CH ₄	8.6	15.2
C ₂ H ₂	0.2	0.4
C ₂ H ₄	2.4	4.2
C ₂ H ₆	0.1	0.2
C ₆ H ₆	0.07	0.1
Tar (C ₁₀ H ₈)	0.1	0.2
NH ₃	0.2	0.3
H ₂ S	0.04	0.1
H ₂ :CO molar ratio	0.59	
Stoichiometric ratio	1.047	
Gasifier Efficiency	75.3% HHV ^a basis	
	74.9% LHV ^b basis	

^a Higher Heating Value. ^b Lower Heating Value.

2.3 Gas Cleanup & Conditioning – Area 300

This section of the process cleans and conditions the syngas so that the gas can be synthesized into methanol. In Area 300, the tars and hydrocarbons in the syngas are reformed to additional CO and H₂. Particulates are removed by quenching. Acid gases (CO₂ and H₂S) are removed, and the syngas is compressed.

The gas from the secondary gasifier cyclone is sent to the catalytic tar reformer (R-303), shown in PFD-P850-A301. In this fluidized bed reactor the hydrocarbons are converted to CO and H₂ while NH₃ is converted to N₂ and H₂. In the Aspen simulation, the conversion of each compound is set to match targets that are believed to be attainable through near-term research efforts. Table 8 gives the experimental conversions (for deactivated catalyst) that have been achieved at NREL (Phillips et al. 2004; Dutta and Aden 2008) and the conversions used in the simulation corresponding to the 2012 research targets. Section 4.2 includes PGP information if the tar reformer conversions from Phillips et al. 2004 are used. The composition of the gas leaving the tar reformer in the Aspen simulation is shown in Table 9.

Table 8. Current and Target Design Performance of Tar Reformer

Compound	Experimental Conversion to CO and H ₂	Target Conversion to CO and H ₂
Methane (CH ₄)	50%	80%
Tars (C ₁₀₊)	99.6%	99.9%
Benzene (C ₆ H ₆)	97.9%	99%

Table 9. Tar Reformer Conditions and Outlet Gas Composition

Tar Reformer Variable	Value	
Tar reformer inlet temperature	1,622°F (883°C)	
Tar reformer outlet temperature	1,622°F (883°C)	
Tar Reformer Outlet Gas Composition	mol % (wet)	mol % (dry)
H ₂	45.26	54.55
CO ₂	8.05	9.70
CO	27.48	33.12
H ₂ O	17.03	--
CH ₄	1.42	1.71
C ₂ H ₂	0.02	0.024
C ₂ H ₄	0.18	0.22
C ₂ H ₆	9.74 ppmv	11.74 ppmv
C ₆ H ₆	4.56 ppmv	5.50 ppmv
Tar (C ₁₀ H ₈)	0.83 ppmv	1.00 ppmv
NH ₃	0.01	0.012
H ₂ S	0.03	0.036
N ₂	0.52	0.63
H ₂ :CO molar ratio	1.65	
Stoichiometric number - (H ₂ -CO ₂)/(CO+CO ₂)		1.04

The hot syngas is cooled through heat exchange with the steam cycle (H-301A-H) and with cooling water via scrubbing, shown in PFD-P850-A302. The scrubbing system consists of a venturi scrubber (M-302) and a quench chamber (M-301). It removes impurities such as particulates and ammonia along with any residual tars. The scrubbing system quench water is a closed recirculation loop with heat rejected to the cooling tower and a blowdown rate of approximately 82.4 gpm (311.9 L/min) sent to a wastewater treatment facility. Any solids that settle out in T-301 are sent off-site for treatment as well.

The steam reformer has a significant water-gas-shift potential because of its nickel-based catalyst. On a single pass system at NREL, the H₂:CO ratio has reached 4:1 under some operating conditions. This extent of WGS is not necessarily the best scenario for making methanol because it also produces 1 mole of CO₂ for every mole of H₂ made. The CO₂ in the syngas must be removed to achieve the specified level of 5 vol % at the synthesis reactor. Carbon utilization to the desired final product can be improved by recycling unreacted syngas back to the synthesis reactor inlet. However, inerts in the gas limit the amount of gas that can be recycled, especially with the CO₂ limitation. Purging a portion of the recycle stream is used to reduce the buildup of inerts, but it also slightly decreases the available syngas utilization.

The quench step cools the syngas to a temperature of 140°F (60°C). The syngas is then compressed using a five-stage centrifugal compressor (K-301) with interstage cooling as shown in PFD-P850-A303. The compressor was modeled such that each section has a polytropic efficiency of 78% and an intercooler outlet temperature of 140°F (60°C). The interstage coolers are forced air heat exchangers. The syngas leaving the compressor is at 750 psi (5.2 MPa) (Phillips et al. 2007).

A low temperature shift (LTS) process (R-434) was added to the model after syngas compression, as shown in PFD-P850-A401. A design specification in the Aspen Plus model was used to divert only as much syngas as needed to meet a H₂:CO ratio of 2.1 (mole basis). The stream to the LTS was mixed with enough superheated steam at 900°F (482°C) to give a steam:CO ratio of 1.0 (mole basis). The LTS effluent has an H₂:CO ratio of 6.38 and a CO₂ mole percentage of 23.3%. The low temperature shift is completed in a single stage. It contains a copper based catalyst that contains reactive zinc oxide, which traps sulfur in the top of the bed as zinc sulfide and prevents sulfur poisoning (Twigg 1996).

To meet the various conditions and expectations for product yields, a process with various recycle streams was designed. An amine-based CO₂ removal step (acid gas removal or AGR) was left in the process design from the EDR model, with similar operating conditions and energy requirements, as shown in Table 10. The AGR separator (S-310) is shown in PFD-P850-A304. The gas is sent to AGR just before entering the methanol synthesis reactor to ensure that the gas entering the synthesis reactor is at the accepted levels of CO₂ and H₂S.

Table 10. Acid Gas Removal Design Parameters

Acid Gas Removal Parameter	Value
Amine used	Monoethanolamine (MEA)
Amine concentration	35 wt %
Amine circ. rate	2,261.5 gpm (8,559.8 L/min)
Amine temp. @ absorber	110°F (43.3°C)
Absorber pressure	735 psia (5.1 MPa)
Stripper condenser temperature	212°F (100°C)
Stripper reboiler temperature	230°F (110°C)
Stripper pressure	65 psia (449 kPa)
Stripper reboiler duty	162 MMBtu/h (171 GJ/h)
Stripper condenser duty	108 MMBtu/h (114 GJ/h)
Amine cooler duty	54.3 MMBtu/h (57.3 GJ/h)
Heat duty per pound CO ₂ removed	2,650 Btu/lb (6.19 MJ/kg)
CO ₂ removed	61,170 lb/h (27,746 kg/h)

CO₂ removed in the scrubber is vented to the atmosphere. Prior to CO₂ removal, the syngas stream needs to be compressed. The higher pressure improves the amine-CO₂ equilibrium and gives better performance and lower energy requirements. A pressure of 735 psia (5.1 MPa) is used. The syngas must be quenched to remove any condensable material, primarily steam, prior to the compression step.

The acid gases removed in the amine scrubber are then stripped to regenerate the sorbent and sent through a sulfur removal operation using a liquid phase oxidation process shown in PFD-P850-A305. The combined amine/LO-CAT process will remove the sulfur and CO₂ to the levels desired for the copper/zinc oxide/alumina catalyst. Although there are several liquid-phase oxidation processes for H₂S removal and conversion available today, the LO-CAT process was selected because of its progress in minimizing catalyst degradation and for its environmentally-benign catalyst. LO-CAT is an iron chelate-based process that consists of a venturi precontactor (M-303), liquid-filled absorber (M-304), air-blown oxidizer (R-301), air blower (K-302), solution circulation pump (P-303), and solution cooler (H-305). The air flow rate for re-oxidizing the LO-CAT solution was included in the simulation and calculated based on the requirement of 2 moles O₂ per mole H₂S. Prior to entering the LO-CAT system, the gas stream is superheated in the preheater (H-304) to 10°F (5.6°C) above its dew point, which in this process is equivalent to 148°F (64.4°C). This degree of superheating is required for the LO-CAT system. The LO-CAT process was modeled to remove the H₂S to a concentration of 10 ppmv, which is the permissible exposure limit (University of Wisconsin 2007) in the CO₂ vent effluent from the amine scrubber. The CO₂ from the LO-CAT unit is vented to the atmosphere (Phillips et al. 2007).

The specified limit for sulfur in the syngas was set at 0.1 ppmv, as per the literature. We assumed that this level could be achieved with the AGR removal system because it is also suitable to H₂S removal. In practice, a ZnO guard bed would likely be used to protect the synthesis catalyst. Omitting the ZnO guard bed is not expected to impact the production cost calculated in this study. A sensitivity analysis that included the cost of the ZnO guard bed and the ZnO catalyst was run and concluded \$0.00 increase to the PGP (set-up for ZnO guard bed found in Shumake and Small 2006).

2.4 Methanol Synthesis – Area 400

The cleaned and conditioned syngas is converted to methanol in a fixed bed reactor (R-490) containing a copper/zinc oxide/alumina catalyst, shown in PFD-P850-A403. The mixture of methanol and unconverted syngas is cooled through heat exchange with the steam cycle and other process streams. The liquid methanol is recovered by condensing it (H-411-414) and separating the liquids from the residual syngas (S-414). Almost 87 wt % of the unconverted syngas is recycled back to the entrance of the synthesis reactor (Hamelinck and Faaij 2002). This is one difference between the BTG process and the EDR method, which had no direct recycle to the synthesis reactor.

To maintain consistency with the EDR, the same type of synthesis reactor was used in this study. However, multiple reactors in series with interstage cooling could be an alternative reactor configuration that may increase methanol yields. Table 11 lists the methanol synthesis conditions for a typical copper/zinc oxide/alumina catalyst given in Bartholomew (Bartholomew and Farrauto 2006). The methanol reaction is fast, and equilibrium is quickly achieved. The heat released during the reaction is a serious concern, because even short excursions of only a few degrees can seriously damage the catalyst irreparably. For this level of study, a kinetics model was not warranted; the temperature was assumed to be isothermal. A REQUIL model was used in the Aspen Plus model. The literature notes that CO₂ concentrations of up to 7 vol % can improve productivity to methanol (Lee 1990). Excessive levels of CO₂ decrease conversion. A value of 5 vol % CO₂ was chosen because that was the level used in the EDR.

Table 11. Process Conditions for Methanol Synthesis

Parameter	“State of Technology” Conditions	Conditions Used in Process Design & Aspen Model
Temperature (°C)	~ 300 (572°F) ^a	300 (572°F)
Pressure (psia)	735 (5.1 MPa) ^a	735 (5.1 MPa)
H ₂ :CO ratio	2 ^b	2.1
CO ₂ concentration (mol %)	3%–8% ^a	5.0%
Sulfur concentration (ppmv)	< 0.1 ^a	0.09
Stoichiometric Number - (H ₂ -CO ₂)/(CO+CO ₂)	2 ^b	1.73
H ₂ /(2CO+3CO ₂)	1.05 ^a	0.87

^a Bartholomew & Farrauto 2006. ^b Olah et al. 2006.

The operating pressure to make methanol is significantly lower than that for making mixed alcohols (735 psia [5.1 MPa] vs. 1,000–2,000 psia [6.9–13.8 MPa]) (Phillips et al. 2007). The temperature is comparable to other synthesis reactions. The desire to have a stoichiometric number of approximately 2 with a concomitant CO₂ concentration of 5%, along with a desire to maximize fuel production (vs. making electricity), poses a design challenge to find the best economic conditions.

Boiler feed water was assumed to be cross-exchanged within the reactor to generate steam for the process. Other reactor designs (e.g., slurry bubble reactors) were not considered at this time, but they do merit investigation because they are reported to have good heat management characteristics.

While productivity was not specified within the Aspen model, methanol synthesis catalysts have been reported to have productivity values of more than 1,000 g/L-cat/h, with 99% or better selectivity to methanol. Given the high selectivity reported in the literature, no other byproducts were assumed in this design, especially because any byproducts are reported to be converted by the downstream MTG process, though there could be exceptions.

2.5 Methanol Conditioning – Area 500

The vapor-phase product from the synthesis reactor must be cooled to recover the methanol and to allow unconverted syngas and any inert gaseous species (CO₂, CH₄) to be recycled or purged. Cooling water is used to lower the temperature to 90°F (32°C) (H411-414), a temperature at which a majority of the liquid methanol condenses and is separated in a knock-out vessel (S-471). About 2,600 lb/h (1,180 kg/h) of methanol, or 3% of the total methanol, is not recovered from the product stream at this temperature.

The methanol is still at elevated pressure at this point in the process, resulting in a significant quantity of gas being absorbed in the methanol stream as it leaves the synthesis section of the process. These gases are removed from the methanol at this stage of the process and are then recycled to the reformer inlet. It may be possible to remove the gases at a later stage in the process. Removal at this point in the process was for modeling convenience, because the stream could be mixed back into the unreacted syngas stream from the synthesis condensation train. The combined gas streams are heated (H-505) before expansion through a turbo expander generator (K-501) to recover some of the compression energy of the gas by generating electricity, shown in

PFD-P850-A502. About 4% of this recycled syngas and other dissolved gases are purged into the fuel gas stream to prevent an accumulation of inert gases. The degassed methanol product is sent to a storage tank (T-592) for short-term surge buffering between the synthesis and MTG sections of the plant.

The composition of this methanol product is shown in Table 12. After the degassing step, the product is nearly 96% methanol, with the remainder being mainly CO₂ and water and small amounts of various components.

Table 12. Composition of Crude Methanol Intermediate in Model

	NREL Model (vol %)
Methanol	95.9%
CO ₂	2.3%
H ₂ O	1.4%
Others	0.4%

2.6 Methanol to Gasoline Conversion (MTG) – Area 1400

In the methanol-to-gasoline (MTG) process, methanol is reacted over a ZSM-5 zeolite catalyst. Prior to conversion, the crude methanol from the intermediate storage tank is pumped into the MTG process to raise the liquid pressure to 200 psia (1.4 MPa). The methanol is then passed over the ZSM-5 zeolite catalyst in a fluidized bed reactor (R-1410), as shown in PFD-P850-1401. The reactor has a riser, a disengaging vessel, and cyclones located above the fluidized bed. In the fluidized bed reactor, the catalyst is continuously withdrawn and regenerated by partially burning off some of the coke (Mokrani and Scurrrell 2009). The regenerator is a combustor type in which carbon deposited on the catalyst is burned off by an upward air stream. The catalyst returns via a slide valve. Therefore, no additional reactors are necessary, in contrast with the fixed bed case. No provisions for catalyst regeneration were considered in this stage of the MTG process. Table 13 lists the reaction conditions and yields for the MTG process.

Table 13. MTG Reaction Conditions and Yields

Temperature	°C (°F)
Reactor inlet	330 (625)
Reactor outlet	400 (752)
Pressure	MPa (psia)
Reactor inlet	1.45 (210)
Reactor outlet	1.28 (185)
Yield	wt %
Hydrocarbons	44
Water	56
Total	100
Crude Hydrocarbon Product	wt %
Light gas	2
Propane	5
Propylene	1
Isobutane	7
n-Butane	5
Butenes	1
C5+ gasoline	79
Total	100
Finished Fuel Products	wt %
Gasoline	82
LPG	10
Fuel gas	8
Total	100

The Aspen model did not include all 51 MTG process products listed in the literature (see Appendix B). Key components such as benzene, durene, and light hydrocarbons were included because their specific fate is important to the final product quality and process heat integration. In the gasoline boiling range above C5 hydrocarbons, some isomers were lumped together because they will all be included in the final product and will stay together through the fractionation steps. Butanes and butenes were included because they are on the edge of acceptability for the gasoline product; too much of the C4 hydrocarbons can cause the RVP to exceed allowable limits.

2.7 Gasoline Separation – Area 1500

The separation of the gasoline mixture is similar to a typical gasoline refinery finishing section, as shown in Figure 1 and in the following PFD's: PFD-P850-1501, -1502, and -1503. The design used in this model came from the New Zealand MTG demonstration process design with a few modifications. Other designs are possible.

The first separation in this section is to remove the lighter hydrocarbons from the gasoline (de-ethanizer/de-propanizer) stream. This is done in the de-ethanizer column (D-1503). The

overhead from this column contains about 50 wt % C₄+ hydrocarbons, which need to be recovered. The overhead goes to an absorber column (D-1502) that uses lean oil from a downstream column as the absorbing liquid. The lean oil and absorbed hydrocarbons are fed back to the de-ethanizer column (D-1503) as reflux to strip out any light hydrocarbons captured in the absorber bottoms effluent.

The bottoms product from the de-ethanizer (D-1503) is sent to a stabilizer column (D-1504) to remove the butanes. The column is operated to remove most of the butanes from the gasoline, thus “stabilizing” it. The overhead product is sent to an alkylation unit (R-1505), and the bottoms product is sent to a splitter column (D-1505) to split the stabilized gasoline into light and heavy gasoline fractions. A side draw from the splitter is sent to the absorber (D-1502) to provide reflux liquid for that column.

The bottoms of the gasoline splitter, consisting mainly of higher hydrocarbons and aromatics, could be sent to an isomerization reactor (R-1500) to convert 1,2,4,5-tetramethylbenzene (durene) into 1,2,3,5-tetramethylbenzene. The former product (durene) has a relatively high freezing point and will crystallize in fuel systems if the concentration exceeds about 5 vol %. The isomer product has a lower freezing point. The effluent from the isomerization reactor would be sent to tank storage. The 1978 DOE report states that the isomerizer uses a small amount of hydrogen (Schreiner 1978). An MTG report from Pacific Northwest National Laboratory (PNNL) accounted for this hydrogen by adding a pressure swing adsorption unit after the methanol synthesis reactor (Jones and Zhu 2009). Other reports have concluded that the isomerizer is not necessary because the MTG gasoline will be added to a very large gasoline stream, thus decreasing the durene concentration to an acceptable level. This is the approach taken in this report. If the isomerizer is added to the process, there is no change in cost to the PGP.

The isomeric mixture of butanes and butenes from the stabilizer is sent to an HF alkylation unit (R-1505) to convert isobutane and butene into isooctane. The effluent from the alkylation unit is sent to a final LPG/alkylate splitter column (D-1506) to separate the unreacted C₄ hydrocarbons from the isooctane. Refrigeration is used to cool the LPG/alkylate splitter. The bottoms product is sent to storage. The final composition of the MTG gasoline from the BTG process is compared to a typical conventional gasoline and to the reported composition for “M-gasoline” from the DOE report in Figure 6 (compositions are also shown in Appendix B). The overhead mixture of butanes is considered a separate product – LPG. The final composition of the LPG is shown in Table 14.

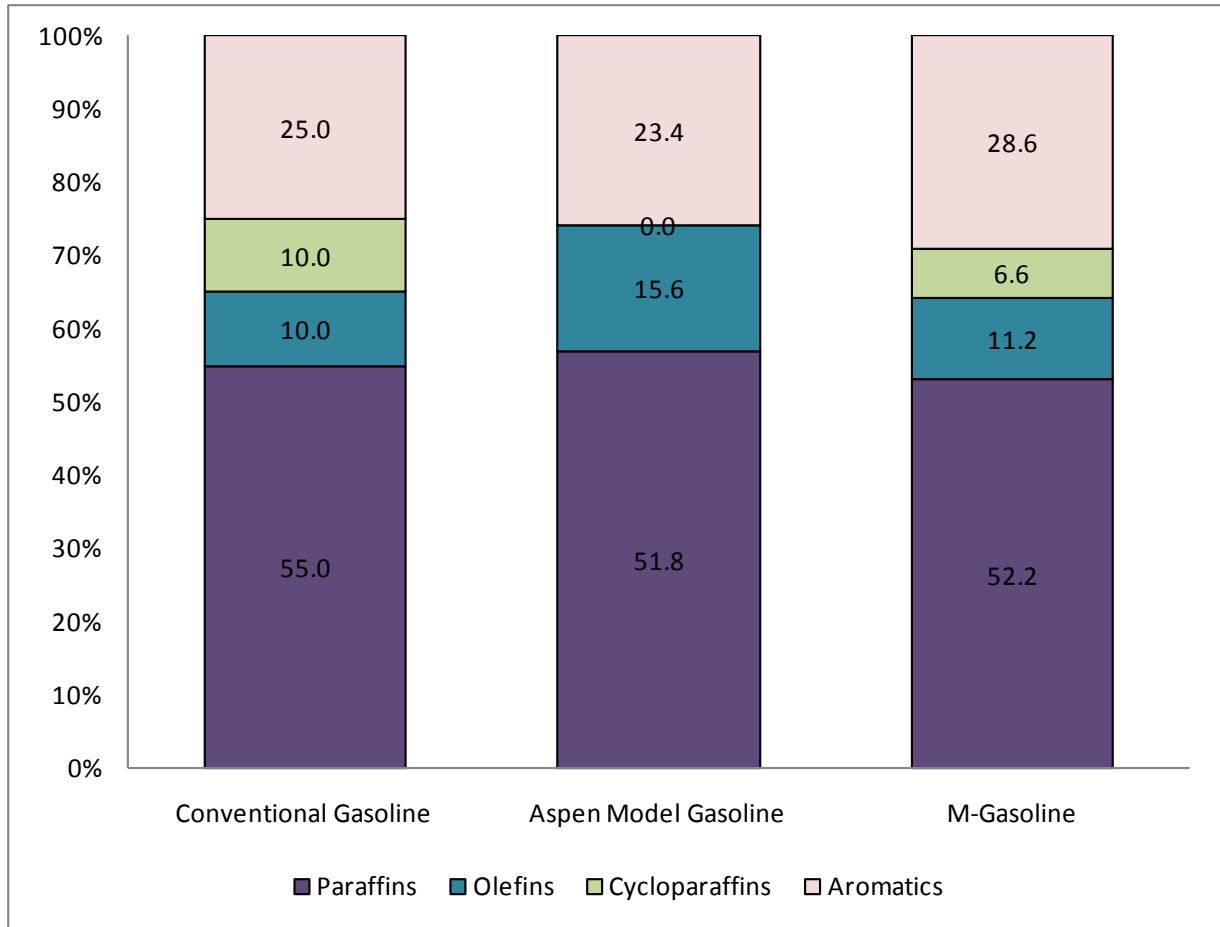

Figure 6. Composition of conventional gasoline wt % (typical)

Table 14. Composition of LPG from Aspen Model

Compound Name	mol %
Propane	28.6
Propene	4.2
i-Butane	42.8
n-Butane	24.4
Water	11 ppmv

The LPG stream could be used to make more gasoline product by using existing technologies to isomerize the n-butane into isobutane and reacting the isobutane with lighter olefins now being sent to the fuel combustor as fuel gas. Alternatively, LPG is a marketable product and could be sold as is, or propane, also a marketable product, could be sold if it is recovered from the fuel gas.

2.8 Steam System and Power Generation – Area 600

This process design includes a steam cycle that produces steam by recovering heat from the hot process streams throughout the plant. Steam demands for the process include the gasifier, amine system reboiler, LO-CAT preheater, and gasoline separation distillation columns. Of these, only

the steam to the gasifier and the steam to the low temperature shift are directly injected into the process; the rest of the plant heat demands are provided by indirect heat exchange of steam with process streams that have condensate return loops. Power for internal plant loads is produced from the steam cycle using an extraction steam turbine/generator (M-602). Power is also produced from the process expander (K-412), which takes the unconverted syngas from 563 psia (3.88 MPa) to 34 psia (234 kPa) before it is recycled to the tar reformer. Steam is supplied to the gasifier from the low pressure turbine exhaust stage. The plant energy balance is managed to generate only the amount of electricity required by the plant. The steam system and power generation area is shown in PFD-P850-A601, -A602, and -A603 in Appendix H.

A condensate collection tank (T-601) gathers condensate from the syngas compressor and from the process reboilers along with the steam turbine condensate and makeup water. The total condensate stream is heated to the saturation temperature and sent to the deaerator (T-603) to remove any dissolved gases out of the water. The water from the deaerator is first pumped to a pressure of 497 psia (3.43 MPa) (P-604) and then pre-heated to its saturation (bubble point) temperature using a series of exchangers. The saturated steam is collected in the steam drum (T-604). To prevent solids buildup, water must be periodically discharged from the steam drum. The blowdown rate is equal to 2% of the water circulation rate. The saturated steam from the steam drum is superheated with another series of exchangers. The superheated steam temperature and pressure were set as a result of thermal analysis. Superheated steam enters the turbine sequence (M-602A, B, C) at 900°F (482°C) and 472 psia (3.25 MPa) and is expanded to a pressure of 176 psia (1.21 MPa). The remaining steam then enters the low pressure turbine and is expanded to a pressure of 65 psia (448 kPa). Here a slipstream of steam is removed and sent to the gasifier and other exchangers. Finally, the steam enters a condensing turbine and is expanded to a pressure of 1 psia (6.89 kPa). The steam is condensed in the steam turbine condenser (H-601), and the condensate is returned to the condensate collection tank.

This model assumes that all drives for pumps, fans, etc. are electric motors. Table 15 contains the power requirement of the plant broken out into the different plant sections. Syngas compression is the largest power requirement for the plant (totaling 22,300 kW, or approximately two-thirds of the plant's power demands). The plant power demands and power production were specifically designed to be nearly equal. Therefore, no excess power is being sold to or purchased from the grid. This plant was designed to be as energy self-sufficient as possible. This was accomplished by burning a portion of the "dirty" unreformed syngas in the fuel combustor (Section 300). While this does have a negative impact on the overall yields of the process, it negates the purchase of natural gas or grid power.

Table 15. Power Requirements for Plant by Process Area

Plant Area	Work, kW
Feed handling & drying	742
Gasification	3,447
Tar reforming, cleanup & conditioning	25,645
LTS, methanol synthesis and degassing	1,993
MTG conversion	57
Gasoline finishing	126
Steam system and power generation	306 required 34,346 generated
Cooling water and other utilities	1,044
Total plant power requirement	33,360

2.9 Cooling Water and Other Utilities – Area 700

The cooling water system is shown in PFD-P850-A701. A mechanical draft cooling tower (M-701) provides cooling water to several heat exchangers in the plant. The tower utilizes large fans to force air through circulated water. Heat is transferred from the water to the surrounding air by the transfer of sensible and latent heat. Cooling water is used in the following pieces of equipment with the associated water demands:

- The sand/ash cooler (M-201), which cools the sand/ash mixture from the gasifier/combustor (698 lb/h [317 kg/h])
- The quench water recirculation cooler (M-301), which cools the water used in the syngas quench step (6,622 lb/h [3,004 kg/h])
- The water-cooled aftercooler (H-303), which follows the syngas compressor and cools the syngas after the last stage of compression (19,829 lb/h [8,994 kg/h])
- The LO-CAT absorbent solution cooler (H-305), which cools the regenerated solution that circulates between the oxidizer and absorber vessels (28 lb/h [12.7 kg/h])
- The reacted syngas cooler (H-414), which cools the gas in order to condense out the liquid methanol (10,025 lb/h [4,547 kg/h])
- The post methanol expander cooler, which cools the methanol prior to degassing (H-504B) (11,846 lb/h [5,373 kg/h])
- The post methanol degassing cooler (H-593) (375 lb/h [170 kg/h])
- Post MTG reactor cooling (H-1414) (803 lb/h [364 kg/h])
- The cooling for various operations conducting gasoline separation (H-1500) (3,178 lb/h [1,442 kg/h]), including:
 - Cooling needed by the absorber column (D-1502)
 - Refrigeration cooling needed by the alkylate/LPG splitter column (D-1506)
 - Finishing cooler for LPG (H-1591)

- Finishing cooler for gasoline (H-1593)
- The cooler for the side draw of the gasoline splitter, which provides reflux liquid to the absorber column (H-1512B) (167 lb/h [76 kg/h])
- The blowdown water-cooled cooler (H-603), which cools the blowdown from the steam drum (2,961 lb/h [1,343 kg/h])
- The steam turbine condenser (H-601), which condenses the steam exiting the steam turbine (118,810 lb/h [53,891 kg/h]).

Makeup water for the cooling tower is supplied at 14.7 psia (101 kPa) and 60°F (16°C). Water losses include evaporation, drift (water entrained in the cooling tower exhaust air), and tower basin blowdown. Drift losses were estimated to be 0.2% of the water supply. Evaporation losses and blowdown were calculated based on information and equations in Perry et al. (1997). The cooling water is supplied to the process at a pressure of 65 psia (448 kPa) and temperature of 80°F (27°C) (Liptak 2005). It returns to the cooling tower at a temperature of 110°F (43°C).

Refrigeration is utilized where cooling is needed below 90°F (32°C). A centrifugal compressor refrigeration system was selected. An instrument air system is included to provide compressed air for both service and instruments. The instrument air system is shown in PFD-P850-A701. The system consists of an air compressor (K-701), dryer (S-701), and receiver (T-701). The instrument air is delivered at a pressure of 115 psia (792 kPa) and a moisture dew point of -40°F (-40°C), and it is oil-free.

Other miscellaneous items that are taken into account in the design include:

- A firewater storage tank (T-702) and pump (P-702)
- A diesel tank (T-703) and pump (P-703) to fuel the front loaders
- An olivine truck scale with dump (M-702) and an olivine lock hopper (T-705) as well as an MgO lock hopper (T-706)
- An ammonia storage tank (T-704) and pump (P-704)
- A hydrazine storage tank (T-707) and pump (P-705) for oxygen scavenging in the cooling water.

This equipment is shown in PFD-P850-A702.

2.10 Additional Design Information

Table 16 contains some additional information used in the Aspen Plus model and the production design.

Table 16. Utility and Miscellaneous Design Information

Item	Design Information
Ambient air conditions ^{a,b,c}	Pressure: 14.7 psia (101 kPa) T _{Dry Bulb} : 90°F (32°C) T _{Wet Bulb} : 80°F (27°C) <u>Composition (mol %):</u> N ₂ : 75.7% O ₂ : 20.3% Ar: 0.9% CO ₂ : 0.03% H ₂ O: 3.1%
Pressure drop allowance	Syngas compressor intercoolers = 2 psi (13.8 kPa) Heat exchangers and packed beds = 5 psi (34.5 kPa)

^a In the GPSA *Engineering Data Book* (GPSA 1987), see Table 11.4 for typical design values for dry bulb and wet bulb temperature by geography. Selected values would cover summertime conditions for most of the lower 48 states.

^b In Weast (1981), see F-172 for composition of dry air. Nitrogen value was adjusted slightly to force mole fraction closure using only N₂, O₂, Ar, and CO₂ as air components.

^c In Perry et al. (1997), see psychrometric chart, Figure 12-2, for moisture content of air.

2.11 Thermal and Pinch Analyses

Thermal and pinch analyses were performed to analyze the energy exchanges throughout the plant. Energy integration is tremendously important to the overall efficiency and economics of the process. Therefore, a detailed understanding of how and where the energy is utilized and recovered is a necessity. The pinch technique was used as a systematic method for confirming that no thermodynamic laws were in violation with the modeled energy integration for the processes. While some heat integration was included, a thorough heat integration optimization was not completed; there is still great room for improvement.

In order to do the pinch analysis, temperature and heat duty data were gathered for streams needing heating or cooling throughout the process. This information was input into Linhoff March SuperTarget software and was utilized to develop the composite curves (temperature vs. enthalpy graph) shown in Figure 7 and to create the Heat Exchanger Network (HEN), shown in Appendix G. The heat exchangers from the HEN are included in the process flow diagrams (PFDs) in Appendix H. However, because these heat exchangers are not included in the Aspen simulation, the stream information to and from the pinch heat exchangers is not shown. The calculated minimum temperature difference across which heat can be transferred (DT_{min}) is 60°F (33°C). The heating and cooling duties are satisfied through process-process interchanges or process-stream interchanges, thus outside utilities are not required. It is expected that any organization considering building a BTG plant would pursue its own heat exchanger network, and thus minor modifications to the heat flows within the system have been made without recreating the heat exchanger network.

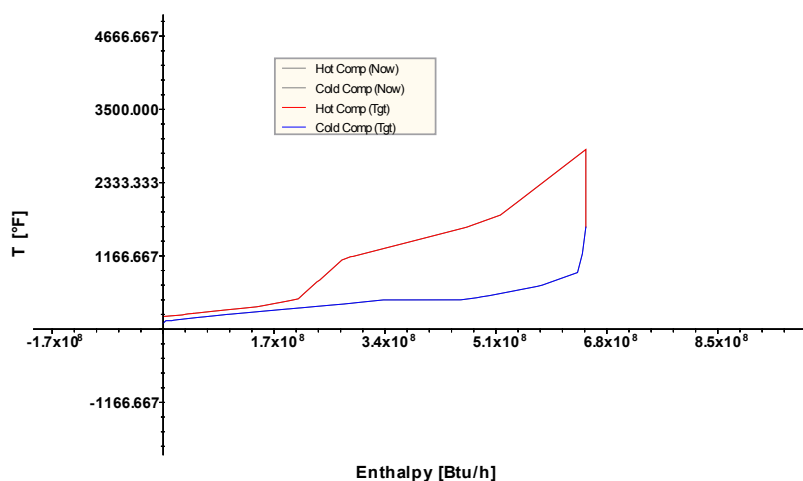

Figure 7. Pinch analysis composite curves

2.12 Water Demands

Water is required as a reactant, a fluidizing agent, and a cooling medium in this process. As a reactant, it participates in reforming and water gas shift reactions. Using the BCL gasifier, it also acts as the fluidizing agent in the form of steam. Its cooling uses are outlined in Section 3.9.

Water usage is becoming an increasingly important aspect of plant design, specifically with regard to today's biofuel plants. Therefore, a primary design consideration for this process was the minimization of fresh water requirements, which therefore meant minimizing the cooling water demands and recycling process water as much as possible. Air-cooling was used in place of cooling water in several areas of the process (e.g., distillation condensers, compressor interstage cooling).

Table 17 quantifies the particular water demands of this design. Roughly 36% of the fresh water demand is for boiler feed makeup, with most of the remainder used as cooling water makeup. Some of this water is directly injected into the gasifier, but other system losses (blowdown) also exist. This process design requires 6.5 gallons of fresh water for each gallon of gasoline produced.

The option of a dry cooling tower exists. The principal advantage of the dry cooling tower is that it significantly reduces or even eliminates the use of water as the cooling medium in the cooling tower. In this case, eliminating the water usage from the cooling tower would lower the process water usage to 2.4 gallons of water per gallon of gasoline. However, the disadvantages of the dry cooling tower are the increase in capital costs and increase in power consumption (information on dry cooling towers can be found in the Public Interest Energy Research (PIER) Program Project Summary [California Energy Commission 2002]).

Table 17. Process Water Demands

Fresh Water Demands lb/h (kg/h)	Dry Cooling Tower	Wet Cooling Tower
Cooling tower makeup	0 (0)	174,716 (79,250)
Boiler feed makeup	100,577 (45,621)	100,577 (45,621)
Sand/ash wetting	243 (110)	243 (110)
Total	100,820 (45,731)	275,536 (124,981)
Overall water demand (gal water / gal gasoline)	2.4	6.5

3 Process Economics

The total project investment (based on total equipment cost) was developed, along with variable and fixed operating costs. From these costs, a discounted cash flow analysis was used to determine the production cost of BTG gasoline. This section describes the cost areas and assumptions made to complete the economic analysis.

Each piece of equipment in these processes was sized based on the mass and energy balance data generated from the Aspen Plus simulation. From this, capital costs (purchase cost) were determined from a variety of sources, including previous studies, Questimate/Aspen IPE software, and engineering consultants (Nexant 2006a-d). Equipment costs from Spath et al. (2005) were used for the front-end sections where the process was virtually the same. The amine system cost was obtained from Nexant. Generalized equipment (heat exchangers, compressors, tanks, pumps, etc.) costs were obtained using Questimate. The fixed-bed methanol synthesis reactor cost was also estimated using Questimate. Distillation columns and other separation units were evaluated individually, and costs were scaled using values taken from the EDR (Phillips et al. 2007). The capital and operating costs of converting the methanol into a finished gasoline product were added to the detailed design. Table 18 gives installed equipment costs by plant area.

Installation cost factors were used to develop a total installed cost (TIC) from the total purchased equipment cost. These factors are identical to those used previously (Spath et al. 2005; Phillips et al. 2007). The same is true for the indirect cost factors used to calculate engineering, construction, legal, and project contingency costs. The costs and cost factors for the current design are shown in Table 19 and Table 20. Costs are in 2007 dollars. This economic analysis does not include any royalties or license fees for use of proprietary technology.

Table 18. Installed Equipment Costs by Process Area

Description of Cost	Installed Cost, MM\$ (\$2007)
Feed handling & drying	\$25.0
Gasification	\$14.6
Tar reforming & quench	\$27.4
Acid gas & sulfur removal	\$12.1
Methanol synthesis - compression	\$10.5
Methanol conditioning/degassing	\$4.8
MTG process	\$21.6
Steam system & power generation	\$23.1
Cooling water & other utilities	\$5.9
Total installed equipment cost	\$145.0
Indirect costs	\$54.6
(% of TPI)	27.4%
Project contingency	\$4.2
Total project investment (TPI)	\$199.6

Table 19. General Cost Factors in Determining Total Installed Equipment Costs

	% of TPEC
Total purchased equipment cost (TPEC)	100
Purchased equipment installation	39
Instrumentation and controls	26
Piping	31
Electrical systems	10
Buildings (including services)	29
Yard improvements	12
Total installed cost (TIC)	247

The indirect costs (non-manufacturing, fixed-capital investment costs) were also estimated using cost factors as per Spath et al. (2005). The factors are shown in Table 20 and have been put in as percentages in terms of total purchased equipment cost, total installed cost (TIC), and total project investment (TPI is the sum of the TIC and the total indirect costs).

Table 20. Cost Factors for Indirect Costs

Indirect Costs	% of TPEC	% of TIC	% of TPI
Engineering	32	13	9
Construction	34	14	10
Legal and contractors fees	23	9	7
Project contingency	7.4	3	2
Total indirect costs	96.4	39	28

Table 21 shows the breakdown of operating cost contribution to PGP. The first column of numbers is based on the total thermal energy of products. The second column is based on gasoline product. The last column is the percentage of the total contribution for each line.

Table 21. Breakdown of Operating Cost Contribution to PGP

Operating Costs	Cents/MMBtu Products (Cents/GJ Products)	Cents/Gal Gasoline (Cents/L Gasoline)	% of PGP
Feedstock	692.1 (656.0)	81.3 (21.5)	41.7%
Natural gas	0.0 (0.0)	0.0 (0.0)	0.0%
Catalysts	6.8 (6.5)	0.8 (0.2)	0.4%
Olivine	8.2 (7.8)	1.0 (0.3)	0.5%
Other raw materials	26.9 (25.5)	3.2 (0.9)	1.6%
Waste disposal	10.6 (10.0)	1.2 (0.3)	0.6%
Electricity transfer	0.0 (0.0)	0.0 (0.0)	0.0%
Electricity	0.0 (0.0)	0.0 (0.0)	0.0%
Fixed costs	243.7 (231.0)	28.6 (7.6)	14.7%
Co-product credits	0.0 (0.0)	0.0 (0.0)	0.0%
Capital depreciation	175.0 (165.9)	20.6 (5.4)	10.5%
Average income tax	126.8 (120.2)	14.9 (3.9)	7.6%
Net annual profit (after tax)	369.9 (350.6)	43.4 (11.5)	22.3%
PGP (total)	1,660.1 (1,573.5)	194.9 (51.5)	100.0%

The operating costs used in this analysis are shown in Table 22. The annualized costs of each are shown later. Specific catalyst compositions and costs are generally proprietary and not readily available. All costs have been adjusted to \$2007 from their original values. The fixed operating costs, including labor and maintenance, are given below in Table 24 and Table 25.

No co-product credits were included in Table 21 because co-products already are factored into the final PGP based on their production rate and energy content. This method gave a PGP for LPG of \$1.53/gallon (\$0.40/liter) in \$2007. During 2010, the wholesale market value for propane varied between \$1.30/gallon (\$0.34/liter) and \$1.47/gallon (\$0.39/liter) (EIA 2010). If a \$2009 co-product credit of \$1.35/gallon (\$0.36/liter) is used for LPG (adjusted to \$2007), the PGP for gasoline increases to \$2.00/gallon (\$0.54/liter).

Table 22. Variable Operating Costs

Variable	Information and Operating Cost
Tar reformer catalyst	To determine the amount of catalyst inventory, the tar reformer was sized for a gas hourly space velocity (GHSV) of 2,476/h based on the operation of the tar reformer at NREL's TCPDU, where GHSV is measured at standard temperature and pressure. Initial fill, then a replacement of 0.01% per day of the total catalyst volume. Price: \$6.03/lb ^a (\$13.29/kg)
Methanol synthesis catalyst	Initial fill, then replaced every 4 years based on typical catalyst lifetime. Catalyst inventory based on GHSV of 8,000/h. Price: \$9.69 ^b /lb (\$21.36/kg)
MTG catalyst (ZSM-5)	Initial fill, then replaced every 1 year based on typical catalyst lifetime. Catalyst inventory based on 1.84 ^c lb fresh feed/h/lb catalyst (1.84 kg fresh feed/h/kg catalyst) Price: \$53.40 ^b /lb (\$117.73/kg)
Alkylation catalysts	Hydrofluoric acid: 0.3 lb/bbl ^d total alkylate (9 g/L) Caustic: 0.2 lb/bbl ^d total alkylate (6 g/L) Price: \$1,595/U.S. ton (\$1,758/metric tonne)
Solids disposal cost	Price: \$28.80/U.S. ton (\$31.75/metric tonne)
Diesel fuel	Usage: 10 gallon/h plant-wide use (38 L/h) Price: \$2.20/gallon (\$0.58/liter)
Chemicals	Boiler chemicals – price: \$2.27/lb (\$5.00/kg) Cooling tower chemicals – price: \$1.36/lb (\$3.00/kg) LO-CAT chemicals – price: \$177/metric tonne of sulfur produced (\$161/U.S. ton)
Wastewater	The wastewater is sent off-site for treatment. Price: \$2.44/100 ft ³ (\$0.86/m ³)

^a GAO 2005. ^b Jones and Zhu 2009. ^c Schreiner 1978. ^d Gary and Handwerk 1994.

The cash flow assumptions used in this analysis are shown in Table 23. The PGP, or minimum product selling price necessary to achieve a 10% internal rate of return (IRR) over a 20-year plant life, is estimated by adjusting the value of the products to give an NPV equal to zero. The economic parameters chosen for a cash-flow analysis can have an enormous impact on the overall economics. For example, return on investment (ROI) and debt/equity financing are assumptions that are often debated and that vary from company to company. Although these can be evaluated by using sensitivity analyses, they are often so significant that they mask the PGP sensitivity to research-impacted parameters.

Table 23. Economic Parameters

Assumption	Value
Internal rate of return (after-tax)	10%
Debt/equity	0%/100%
Plant life	20 years
General plant depreciation	200% DDB
General plant recovery period	7 years
Steam plant depreciation	150% DDB
Steam plant recovery period	20 years
Construction period	2.5 years
1st 6 months expenditures	8%
Next 12 months expenditures	60%
Last 12 months expenditures	32%
Start-up time	6 months
Revenues	50%
Variable costs	75%
Fixed costs	100%
Working capital	5% of total capital investment
Land	6% of total purchased equipment cost (cost taken as an expense in the 1st construction year)

Because the salaries listed are not fully loaded (i.e., do not include benefits), a general overhead factor was used. This also covers costs such as general plant maintenance, plant security, janitorial services, and communications. The 2003 PEP yearbook lists the national average loaded labor rate at \$37.66 per hour. Using the salaries in Table 24 along with the 60% general overhead factor from Aden et al. (2002) gave an average loaded labor rate of \$30 per hour. To more closely match the PEP yearbook average, the overhead factor was raised to 95% and the resulting loaded labor rate is \$37.87 per hour (\$2007) (Phillips et al. 2007). The number of plant personnel was adjusted to reflect the additional MTG process areas. In Table 24, these increases are shown in parentheses relative to the EDR values.

Table 24. Labor Costs

Position	Salary	Number	Total Cost
Plant manager	\$110,000	1	\$110,000
Plant engineer	\$65,000	2	\$130,000
Maintenance supervisor	\$60,000	1	\$60,000
Lab manager	\$50,000	1	\$50,000
Shift supervisor	\$45,000	5	\$225,000
Lab technician	\$35,000	4	\$140,000
Maintenance technician	\$40,000	12 (8+4)	\$480,000
Shift operators	\$40,000	30 (20+10)	\$1,200,000
Yard employees	\$25,000	12	\$300,000
Clerks & secretaries	\$25,000	3	\$75,000
Total salaries (\$2002)			\$2,770,000
			(\$2007)
			\$3,580,000

Table 25. Other Fixed Costs

Cost Item	Factor	Cost
General overhead	95% of total salaries	\$3,401,000
Maintenance	2% of total project investment	\$3,992,000
Insurance & taxes	2% of total project investment	\$3,992,000

4 Economics - Results

Using the previously mentioned discounted cash flow parameters and cost information, we calculated a minimum gasoline selling price, or PGP. Results are given based on the specific product values and on a gallon ethanol equivalent (gee) basis for comparison to other processes. No sales prices for co-products were needed for this analysis because all co-products were included in the final PGP based on their production rate and energy content.

The BTG results are shown in Table 26 along with the results from the EDR.

Table 26. Process and Economic Results Summary for 2012 BTG Case

	BTG Process – Price calculated on energy content of all products	EDR^a – As reported in reference
Feedstock rate (plant size), dry metric tonne/day (dry U.S. ton/day)	2,000 (2,205)	2,000 (2,205)
On-line time, h/yr	8,406	8,406
Total yield, gallons/dry U.S. ton (liters/dry metric tonne)	55.1 (229.9) – gasoline 9.3 (38.8) – LPG	80.1 (334.2) – ethanol 94.1 (392.7) – mixed alcohols
Fuel products, MMgal/yr (ML/year)	42.5 (160.9) – gasoline 7.1 (26.9) – LPG	61.8 (233.9) – ethanol 72.6 (274.8) – mixed alcohols
Total project investment (\$MM)	199.6	210.2
PGP or minimum product selling price		
\$/gal gasoline (\$/L gasoline)	\$1.95 (\$0.52)	
\$/gal ethanol equivalent (\$/L ethanol equivalent)	\$1.39 (\$0.37)	\$1.28 (\$0.34)
\$/gal LPG (\$/L LPG)	\$1.53 (\$0.40)	
\$/MMBtu fuel, HHV basis (\$/GJ fuel)	\$16.60 (\$15.73)	
Reference Year dollars	2007	2007
Internal rate of return (IRR)	10%	10%
Feedstock cost, \$/dry U.S. ton (\$/dry metric tonne)	\$50.70 (\$55.89)	\$50.70 (\$55.89)
Equity % of total plant investment	100%	100%
Carbon efficiency to desired product	27.9%	27.2%
Overall plant efficiency (LHV-basis)	42.6%	47.4%

^a As published in the EDR (Phillips et al. 2007) with adjustments to U.S. \$2007 and same feedstock cost of \$50.70/dry U.S. ton (\$55.89/dry metric tonne). Note this PGP is different than the one cited in the OBP MYPP, referenced in the Executive Summary. The difference is attributed to an adjustment made in the alcohol synthesis target.

4.1 Cost Contribution for Gasoline

The contribution of each process area to the PGP is shown graphically in Figure 8. The cost contributions are divided into capital, variable, and fixed operating costs. Feedstock cost is the largest single contributor to the PGP and represents essentially all of the variable operating cost.

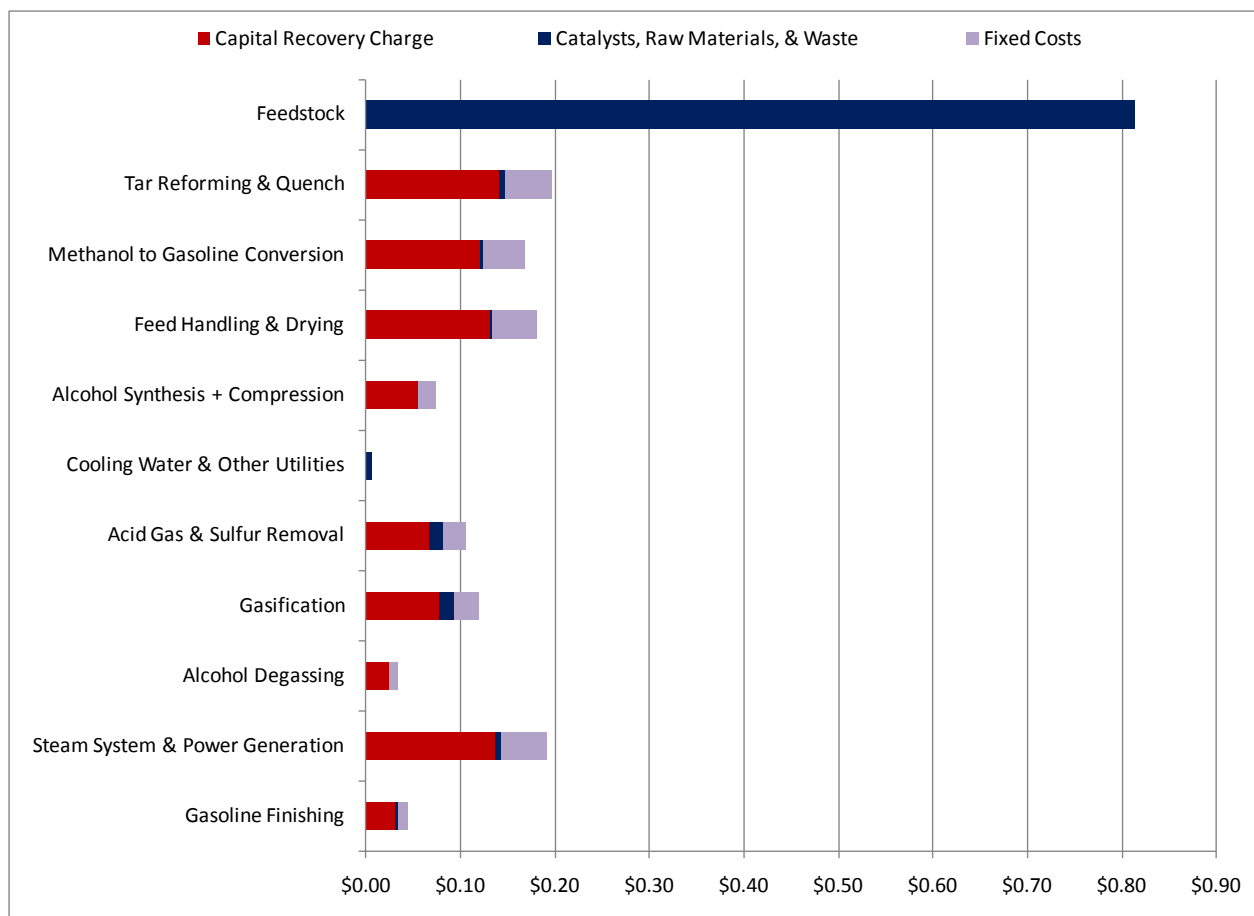

Figure 8. Cost breakdown by area in \$/gallon

4.2 Sensitivity Analyses

Sensitivity analyses were conducted to quantify the cost impacts that various process variables and different process configurations would have on the PGP. We used several methods to evaluate sensitivities in the process model, especially focusing on operating parameters for areas that are not based on commercial processes or costs that are uncertain, such as catalyst costs and lifetimes. A list of the variables considered is shown in Table 27.

Each parameter was changed to a high and a low value as indicated, and the new PGP was calculated. The new PGP can be obtained by multiplying the percent change in PGP, in fraction form, by \$1.95/gallon (\$0.52/liter) of gasoline, and then adding or subtracting the result to or from \$1.95/gallon (\$0.52/liter) of gasoline.

Table 27. List of Variables for Sensitivity Analyses

Process Parameters	Base Values	Parameter Ranges	% Change in Parameter	% Change in PGP
Feedstock cost, \$/ton (\$/tonne)	50.9 (56.1)	20–85 (22–94)	-61 and +66	-26 and +28
Unconverted syngas recycle amount - methanol synthesis, %	87	67–93	-23 and +7	+4 and 0
Other raw materials, \$/MMBtu (\$/GJ)	0.27 (0.26)	0.20–0.34 (0.19–0.33)	-25 and +25	0 and 0
Tar reformer catalyst cost, \$/ton (\$/tonne)	9,340 (10,300)	934–18,680 (1,030–20,590)	-90 and +200	0 and 0
Olivine cost, \$/ton (\$/tonne)	172.9 (190.6)	17.29–345.8 (19.1–381.2)	-90 and +200	-1 and +1
Internal rate of return, %	10	0–30	-100 and +200	-27 and +91
Total project investment, MM\$	199.6	172.1–500	-12 and +150	-3 and +62
Plant size, dry tonne/day (dry ton/day)	2,000 (2,205)	600–10,000 (660–11,000)	-70 and +400	+102 and -38
Feed moisture content, wt %	50	25–70	-50 and +40	-4 and +19
Installation factor	2.47	1.98–3.46	-20 and +40	-3 and +4
H ₂ :CO ratio	2.1	1.47–2.73	-30 and +30	0 and +1
Methanol synthesis catalyst, \$/lb (\$/kg)	8.63 (19.03)	5.25–26.25 (11.57–57.87)	-39 and +204	0 and +1
MTG – ZSM-5 catalyst, \$/lb (\$/kg)	53.4 (117.7)	5.25–150 (11.6–330.7)	-90 and +181	-2 and +5
Stream factor	0.96	0.85–1	-11 and +4	+6 and -2

Feedstock Cost: As the cost by area graph (Figure 8) shows, feedstock cost is a major portion of the overall product cost and the single largest contributor to operating costs. A 38% change in the feed cost (higher or lower) resulted in a 16% change in the PGP. This is illustrated along with other parameters' impact in Figure 9. The more vertical a line is on the graph, the more sensitive the PGP is to a change in the given parameter.

Tar Reforming Conversions: If, instead of the targets, the proven tar reformer conversions (Phillips et al. 2004) are input into the model, the result is a 6% increase in PGP.

Dry Cooling Tower Scenario: If a dry cooling tower is utilized, a 4% increase in PGP is predicted.

Gasoline Yields: If the gasoline yields decrease by 10% there is a 12% increase in the PGP.

Fixed Bed Scenario: A simulation utilizing a fixed bed MTG reactor was used to predict a 33% increase in PGP with a 7.5:1 recycle ratio of gases to methanol (this scenario purchased 27 MW of electricity).

Alkylation: If the alkylation unit is removed the PGP increases by 3%.

Unconverted Syngas Recycle Ratio: To optimize the methanol synthesis process, a high (87%) recycle of unconverted syngas to the methanol synthesis reactor was input into the model. Varying the recycle down to 67% increased the PGP by 4%.

Synthesis Reactor Pressure: The methanol synthesis catalyst and process are commercial with well-established operating parameters. No sensitivity analysis was done on pressure because the operating pressure is not an uncertainty.

Synthesis Reactor CO Conversion: As with the reactor pressure, the performance of the methanol catalysts is well established. No sensitivity analysis was done on CO conversion.

H₂:CO Ratio: The H₂:CO ratio was varied $\pm 30\%$ from the base case level of 2.1. This sensitivity reflects only the impact of making syngas with that ratio. It does not reflect any impacts on the synthesis catalyst from using a different ratio. An H₂:CO ratio less than 2 most likely will have a negative impact on methanol production because it is below the stoichiometric ratio desired for making methanol from CO and H₂. Operating with a higher ratio than 2.1 should not negatively impact the synthesis catalyst performance. The impact of varying this ratio by $\pm 30\%$ resulted in PGP changes of 0%–1%.

Other Synthesis Parameters: Sensitivity analyses were not conducted for the following synthesis parameters: GHSV, temperature, pressure, reactor design, and sulfur concentration. A more rigorous synthesis model, based on kinetic parameters, is needed to have any confidence in a parameter's impact on the methanol production and the resulting PGP for gasoline.

Methanol Condensation Temperature: The impact of using a lower temperature in the methanol condensation train was evaluated. A temperature of 40°F was set for the gas/methanol separation vessel. As a quick estimate, no additions were made to the models to account for the additional equipment and energy costs for chilling the process stream. Although more methanol was collected at 40°F compared to the 90°F used in the base case, the PGP for gasoline was unchanged. Adding the equipment and energy necessary to achieve a 40°F temperature would result in a higher PGP. No attempt was made to adjust the plant's energy and material integration to perhaps improve on the result.

Gasoline Finishing Processes: The process used for finishing the “crude” gasoline from the MTG reactors is primarily distillation, which separates the various fractions and results in a fungible gasoline product. The model used for evaluating this part of the process has highly coupled unit operations. For example, a side draw is taken from the splitter column to provide reflux liquid for the absorber column. The liquid exiting the absorber bottom is pumped to the de-ethanizer column for its reflux liquid. A sizeable amount of butanes and propanes is generated in the process. Opportunities exist for upgrading these paraffins beyond what was done in the current model using available technologies. An alkylation unit was added to the model to form isooctane from isobutane and 2-butene, but straight-chain butanes were not upgraded. The

economic impact of upgrading the butanes should be evaluated to ascertain whether the increased capital and operating expenses would be justified.

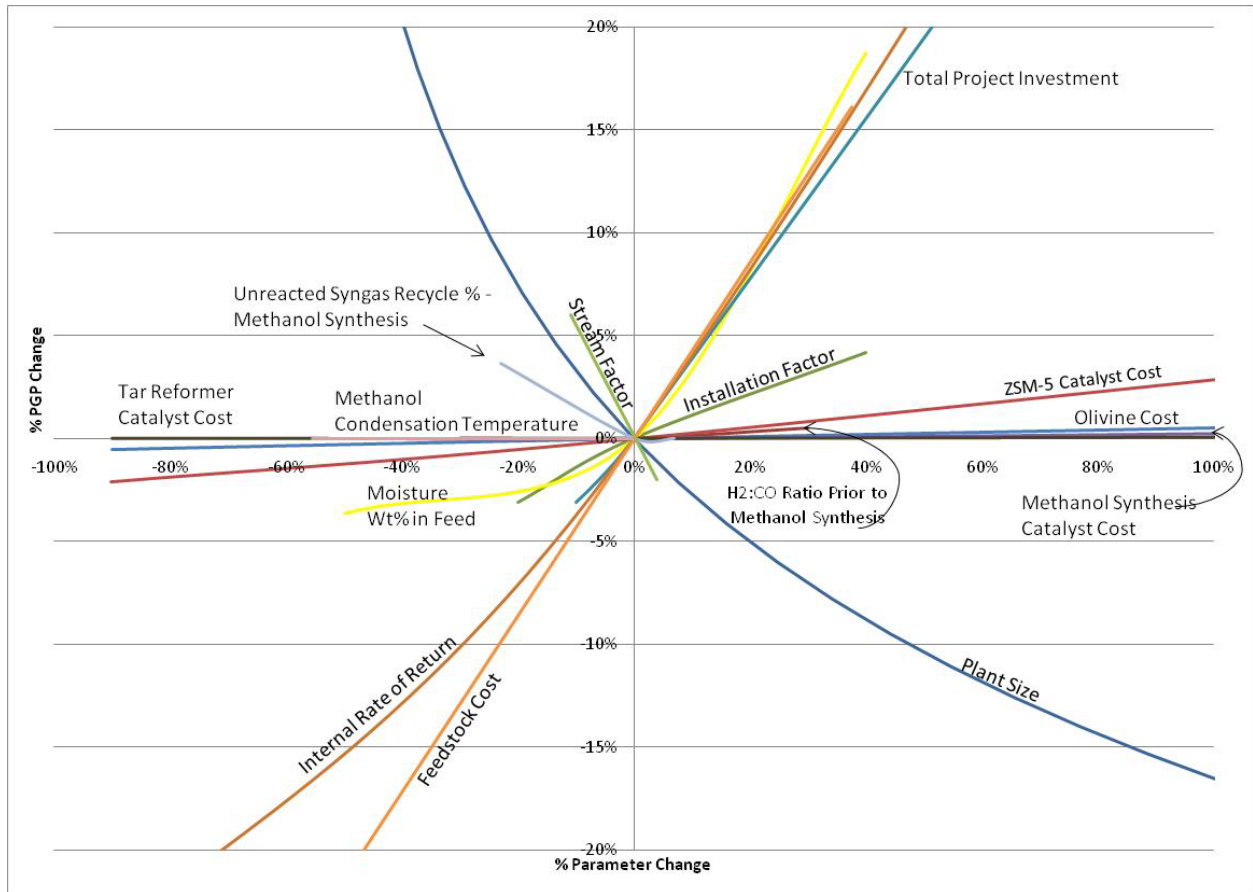

Figure 9. Sensitivity analysis for biomass-to-gasoline process

The horizontal axis in Figure 9 is the percent change in the sensitivity parameter, and the vertical axis is the percent change in the PGP. A more vertical line for the specified variable demonstrates greater volatility on the PGP when variations occur. It is clear that the factors with the greatest impact on the PGP are feedstock cost, feedstock moisture level, plant size, and the economic factors: internal rate of return and total project investment. The gasoline PGP is very much dependent on these factors. As is shown by the horizontal nature of the lines representing the catalyst costs, their contribution to the PGP is minimal, and variations in the catalyst costs should not greatly affect the PGP.

5 Conclusions

This report summarizes the results of a conceptual process design, detailed mass and energy balance model, and economic analysis for gasoline from biomass via gasification, methanol synthesis, and the MTG process. The analysis showed that gasoline could potentially be

produced from a thermochemical biorefinery with a PGP of \$1.95/gallon (\$0.52/liter) (U.S. \$2007). This has a gallon ethanol equivalent (gee) price of \$1.39 (\$0.37 liter ethanol equivalent). The PGP for gasoline on a gee basis is comparable to \$1.57 for ethanol (\$0.41/liter ethanol) from the OBP MYPP. These two values are close enough to be considered the same, given the level of uncertainty in the estimates used in the modeling of both processes. The benefits of one product over the other will likely come from site-specific, local externalities such as shipping costs, fungibility with existing infrastructure (e.g., pipelines), and local markets and preferences.

The process outlined here shares common gasification and tar reforming research needs with the thermochemical ethanol process. The processes downstream of the gas cleaning and conditioning section are significantly different in terms of development. The methanol synthesis process has been commercial for many years and is well established. The MTG conversion process has been demonstrated on a large scale for the fixed bed scenario and on a pilot scale for the fluidized bed scenario, but it is not as widely established as the methanol process. The technology for the fixed bed MTG process is available as a licensed product from ExxonMobil. The gasoline process is a good fit for petroleum companies wanting to add biomass-derived products to their product portfolio. The gasoline from this process is fungible with existing refinery products and infrastructure. Additional analyses should investigate the economic feasibility of increasing alkylate production from light hydrocarbons – technologies that are well known by petroleum refiners and technology vendors.

In conclusion, the results from this preliminary evaluation indicate great potential for producing gasoline from biomass via thermochemical biomass conversion to syngas and the MTG process, and thus warrant a more detailed study. Future work areas of interest include obtaining better process information on the MTG section of the plant, especially equipment and operating costs; increasing the heat integration throughout the process; scale-up of the MTG fluidized bed reactor; testing the MTG reactor and catalyst with methanol from biomass-derived syngas; testing of the MTG fluidized bed reactor at higher pressure; and evaluating the possibility of selling raw MTG gasoline and refining it in an existing refinery.

6 Acknowledgments

This work was supported by the U.S. Department of Energy's Biomass Program, under Contract DE-AC36-08-GO28308 with the National Renewable Energy Laboratory. Colleagues at NREL have contributed to and assisted in developing many of the models and tools that were the starting point for this work. Major contributors to the model on which this paper is based were Dr. Richard Bain, Pamela Spath, Andy Aden, and John Jechura. Editing was provided by Sara Havig, NREL Communications Office. Many useful and insightful comments were provided by internal reviewers, Andy Aden and Dr. Richard Bain, and external reviewers Dr. Robert Brown at Iowa State University, Dr. Nicholas Petrellis, a chemical processing technologies consultant and recently retired from BP, Peter Tijm at PV Enterprises, Inc., and Jim Wykowski and Dave Payton at GEMI, University of Houston. Thank you to all contributors.

7 References

- Aden, A.; Ruth, M.; Ibsen, K.; Jechura, J.; Neeves, K.; Sheehan, J.; Wallace, B.; Montague, L.; Slayton, A.; Lukas, J. (June 2002). *Lignocellulosic Biomass to Ethanol Process Design and Economics Utilizing Co-Current Dilute Acid Prehydrolysis and Enzymatic Hydrolysis for Corn Stover*. NREL/TP-510-32438. Golden, CO: National Renewable Energy Laboratory.
<http://www.nrel.gov/docs/fy02osti/32438.pdf>.
- Aden, A.; Spath, P.; Atherton, B. (September 2005). *The Potential of Thermochemical Ethanol Via Mixed Alcohols Production*. NREL Milestone Report. Golden, CO: National Renewable Energy Laboratory. <http://biodev.nrel.gov/bcfcdoc/9432.doc>.
- Bain, R. (January 1992). *Material and Energy Balances for Methanol from Biomass Using Biomass Gasifiers*. NREL/TP-510-17098. Golden, CO: National Renewable Energy Laboratory.
- Bain, R. (2005). *The Role of Thermochemical Processing in an Integrated Sugars/Thermochemical Biorefinery: Conceptual Process Technoeconomic Analysis*. NREL Technical Memo. Golden, CO: National Renewable Energy Laboratory.
<http://devafdc.nrel.gov/bcfcdoc/8967.doc>.
- Bartholomew, C. H.; Farrauto, R. J. (2006). *Fundamentals of Industrial Catalytic Processes*. Hoboken, NJ: John Wiley.
- Bem, J. (1985). "New Zealand Synthetic Gasoline Plant." *Proceedings of the 20th Intersociety Energy Conversion Engineering Conference* (1); pp. 517-522.
- Biomass Intel. (February 2010). "EPA Finalizes RFS2, Obama Charts Biofuels Pathway." <http://www.biomassintel.com/update-epa-finalizes-rfs2-obama-charts-aggressive-biofuels-path/>. Accessed May 26, 2010.
- Biomass Research and Development Board. (October 2008). National Biofuels Action Plan. 24 pp. Washington, DC: U.S. Department of Energy and U.S. Department of Agriculture.
<http://www1.eere.energy.gov/biomass/pdfs/nbap.pdf>.
- BusinessWire. (29 September 2008). "Exxon Mobil's Methanol-to-Gasoline (MTG) Technology Selected for Synthesis Energy Systems' Coal to Liquids Projects." http://www.businesswire.com/portal/site/home/permalink/?ndmViewId=news_view&newsId=20080929006389&newsLang=en. Accessed May 17, 2010.
- California Energy Commission. (2002). "PIER PROGRAM Project Summary." Web site of the California Energy Commission.
http://www.energy.ca.gov/research/environmental/project_fact_sheets/100-98-001-6.html. Accessed January 22, 2009.
- Chang, C. D. (1992). "The New Zealand Gas-to-Gasoline Plant: An Engineering Tour de Force." *Catalysis Today* (13:1); pp. 103-111.

Chemical Engineering. (October 2006). "Plant Cost Index-Economic Indicators." *Chemical Engineering*. http://www.che.com/business_and_economics/economic_indicators.html.

Craig, K. R.; Mann, M. K. (October 1996). *Cost and Performance Analysis of Biomass-Based Integrated Gasification Combined-Cycle (BIGCC) Power Systems*. NREL/TP-430-21657. Golden, CO: National Renewable Energy Laboratory. <http://www.nrel.gov/docs/legosti/fy97/21657.pdf>.

DKRW Advanced Fuels. (18 December 2007). "DKRW Advanced Fuels Secures ExxonMobil MTG Technology: Industrial Siting Permit Granted." Press Release. http://www.dkrwenergy.com/filelib/FileCabinet/Media_Kit/MedBowReleaseFinal.pdf?FileNme=MedBowReleaseFinal.pdf. Accessed May 17, 2010.

Dutta, A.; Phillips, S. (2009). *Thermochemical Ethanol via Direct Gasification and Mixed Alcohol Synthesis of Lignocellulosic Biomass*. NREL/TP-510-45913. Golden, CO: National Renewable Energy Laboratory.

Edwards, M.; Avidan, A. (1986). "Conversion Model Aids Scale-Up of Mobil's Fluid Bed MTG Process." *Chemical Engineering Science* (41:4); pp. 829-835.

Energy Information Administration (EIA). (2010). Heating Oil and Propane Update. <http://www.eia.doe.gov/oog/info/hopu/hopu.asp>. Accessed November 23, 2010.

Foust, T. D.; Wooley, R.; Sheehan, J.; Wallace, R.; Ibsen, K.; Dayton, D.; Himmel, M.; Ashworth, J.; McCormick, R.; Melendez, M.; Hess, J. R.; Kenney, K.; Wright, C.; Radtke, C.; Perlack, R.; Mielenz, J.; Wang, M.; Synder, S.; Werpy, T. (2007). *A National Laboratory Market and Technology Assessment of the 30 x 30 Scenario*. NREL/TP-510-40942. Golden, CO: National Renewable Energy Laboratory.

GAO. (June 2005). *Gasoline Markets – Special Gasoline Blends Reduce Emissions and Improve Air Quality, but Complicate Supply and Contribute to Higher Prices*. GAO-05-421, Report to Congressional Requesters. Washington, DC: United States Government Accountability Office.

Garrett, D. E. (1989). *Chemical Engineering Economics*. New York, NY: Van Nostrand Reinhold.

Gary, J. H.; Handwerk, G. E. (1994). *Petroleum Refining: Technology and Economics*. New York, NY: Marcel Dekker.

Gas Processors Suppliers Association (GPSA). (1987). *GPSA Engineering Data Book*, Tenth Edition. Tulsa, OK: Gas Processors Suppliers Association.

Gayubo, A. G.; Ortega, J. M.; Aguayo, A. T.; Arandes, J. M.; Bilbao, J. (August 2000). "MTG Fluidized Bed Reactor-Regenerator Unit with Catalyst Circulation: Process Simulation and Operation of an Experimental Setup." *Chemical Engineering Science* (55:16); pp. 3223-3235.

Haddeland, G. (1981). *Methanol (Supplement B)*. Menlo Park, CA: SRI International.

Haggin, J. (1985). "First Methanol-to-Gasoline Plant Nears Startup in New Zealand." *Chemical & Engineering News* (March 25, 1985); p. 39.

Haggin, J. (1987). "Methane-to-Gasoline Plant Adds to New Zealand Liquid Fuel Resources." *Chemical & Engineering News* (June 22, 1987); p. 22.

Haldor Topsoe. (2010). Gasoline – TIGAS. Web page.
http://www.topsoe.com/business_areas/gasification_based/Processes/Gasoline_TIGAS.aspx.
Accessed July 29, 2010.

Hamelinck, C. N.; Faaij, A. P. C. (2002). *Future Prospects for Production of Methanol and Hydrogen from Biomass*. Utrecht, the Netherlands: Department of Science, Technology and Society, Utrecht University.

Hutson, T. Jr.; Hays, G.E. (1977). "Reaction Mechanisms for Hydrofluoric Acid Alkylation." Chapter 2. Albright, L.F.; Goldbsy, A.R., eds. *Industrial and Laboratory Alkylations*. ACS Symposium Series Vol. 55, Washington, DC: American Chemical Society; pp. 27-56. DOI: 10.1021/bk-1977-0055.ch002.

Jones, S. B; Zhu, Y. (2009). *Techno-economic Analysis for the Conversion of Lignocellulosic Biomass to Gasoline via the Methanol-to-Gasoline (MTG) Process*. PNNL Report No. 18481. Richland, WA: Pacific Northwest National Laboratory.

Kirkpatrick, R. D. (1984). "New Zealand Synthetic Fuels Gas To Gasoline Plant." *ChE* (9); pp. 17-20.

Lee, S. (1990). *Methanol synthesis technology*. Boca Raton, FL: CRC Press.

Liederman, David; Jacob, Solomon M.; Voltz, Sterling E.; Wise, John J. *Process Variable Effects in the Conversion of Methanol to Gasoline in a Fluid Bed Reactor*. Ind. Eng. Chem. Process Des. Dev. Vol. 17 No. 3, 1978.

Liptak, B.G. (2005). *Instrument Engineers Handbook: Process Control and Optimization*, Boca Raton, FL: CRC Press.

Mann, M. K.; Spath, P. L. (1997). *Life Cycle Assessment of a Biomass Gasification Combined-Cycle Power System*. NREL/TP-430-23076. Golden, CO: National Renewable Energy Laboratory. <http://www.nrel.gov/docs/legosti/fy98/23076.pdf>.

Mokrani, T.; Scurrall, M. (January 2009). "Gas Conversion to Liquid Fuels and Chemicals: The Methanol Route-Catalysis and Processes Development." *Catalysis Reviews* (51:1); pp. 1-145.

Nexant Inc. (May 2006a). *Equipment Design and Cost Estimation for Small Modular Biomass Systems, Synthesis Gas Cleanup, and Oxygen Separation Equipment, Task 1: Cost Estimates of Small Modular Systems*. NREL/SR-510-39943. Work performed by Nexant Inc., San Francisco, CA. Golden, CO: National Renewable Energy Laboratory.
<http://www.nrel.gov/docs/fy06osti/39943.pdf>.

Nexant Inc. (May 2006b). *Equipment Design and Cost Estimation for Small Modular Biomass Systems, Synthesis Gas Cleanup, and Oxygen Separation Equipment, Task 2: Gas Cleanup Design and Cost Estimates – Wood Feedstock*. NREL/SR-510-39945. Work performed by Nexant Inc., San Francisco, CA. Golden, CO: National Renewable Energy Laboratory. <http://www.nrel.gov/docs/fy06osti/39945.pdf>.

Nexant Inc. (May 2006c). *Equipment Design and Cost Estimation for Small Modular Biomass Systems, Synthesis Gas Cleanup, and Oxygen Separation Equipment, Task 2.3: Sulfur Primer*. NREL/SR-510-39946 May 2006. Work performed by Nexant Inc., San Francisco, CA. Golden, CO: National Renewable Energy Laboratory. <http://www.nrel.gov/docs/fy06osti/39946.pdf>.

Nexant Inc. (May 2006d). *Equipment Design and Cost Estimation for Small Modular Biomass Systems, Synthesis Gas Cleanup, and Oxygen Separation Equipment, Task 9: Mixed Alcohols From Syngas — State of Technology*. NREL/SR-510-39947. Work performed by Nexant Inc., San Francisco, CA. Golden, CO: National Renewable Energy Laboratory. <http://www.nrel.gov/docs/fy06osti/39947.pdf>.

NREL. (2003). *Stage Gate Management in the Biomass Program*. April 2003, Revision 1. Golden, CO: National Renewable Energy Laboratory. <http://devafdc.nrel.gov/pdfs/8385.pdf>.

Office of the Biomass Program (OBP). (2008). *Multi-Year Technical Plan*. Washington, DC: U.S. Department of Energy Office of Energy Efficiency and Renewable Energy. <http://www1.eere.energy.gov/biomass/pdfs/mytp.pdf>.

Office of the Biomass Program (OBP). (May 2009). *Biomass Multi-Year Program Plan (MYPP)*. Washington, DC: U.S. Department of Energy Office of Energy Efficiency and Renewable Energy. <http://www1.eere.energy.gov/biomass/pdfs/mypp.pdf>.

Olah, G.A.; Goeppert, A.; Prakash, G.K.S. (2006). *Beyond Oil and Gas, The Methanol Economy*, Weinheim, Germany: Wiley-VCH.

Perlack, R. D.; Wright, L.; Turhollow, A. F.; Graham, R.; Stokes, B. J.; Erbach, D. C. (2005). *Biomass as Feedstock for a Bioenergy and Bioproducts Industry: The Technical Feasibility of a Billion-Ton Annual Supply*. ORNL/TM-2005/66. Oak Ridge, TN: Oak Ridge National Laboratory. http://www1.eere.energy.gov/biomass/pdfs/final_billionton_vision_report2.pdf.

Perry, R. H.; Green, D. W.; Maloney, J. O. (1997). *Perry's Chemical Engineers' Handbook*, 7th ed. New York: McGraw-Hill.

Peters, M. S.; Timmerhaus, K. D. (2003). *Plant Design and Economics for Chemical Engineers*, 5th Edition. New York: McGraw-Hill, Inc.

Phillips, S.; Aden, A.; Jechura, J.; Dayton, D.; Eggeman, T. (2007). *Thermochemical Ethanol via Indirect Gasification and Mixed Alcohol Synthesis of Lignocellulosic Biomass*. NREL/TP-510-41168. Golden, CO: National Renewable Energy Laboratory. <http://www.nrel.gov/docs/fy07osti/41168.pdf>.

Phillips, S.; Carpenter, D.; Dayton, D.; Feik, C.; French, R.; Ratcliff, M.; Hansen, R.; Deutch, S.; Michener, B. (2004). *Preliminary Report on the Performance of Full Stream Tar Reformer*. Internal NREL Milestone Report. Golden, CO: National Renewable Energy Laboratory.

Pine, M. (1984). "New Zealand GTG Plant More than Halfway Home." *Mobil World* (50:4); pp. 6-7.

Probst, R. F.; Hicks, R. E. (1982). *Synthetic Fuels*. New York: McGraw-Hill.

Schreiner, M. (1978). *Research Guidance Studies to Assess Gasoline from Coal by Methanol-to-Gasoline and Sasol-Type Fischer-Tropsch Technologies*. 234 pp. Final report: FE-2447-13. Work performed by Mobil Research and Development Corp., Princeton, NJ. Washington, DC: U.S. Department of Energy.

Seddon, D. (2006). *Gas Usage and Value*. Tulsa, OK: PennWell Corporation.

Shumake, G.; Small, J. (2006). "Mixing Things Up in Hydrogen Plants." *Hydrocarbon Engineering* (November 2006). http://www.cbi.com/images/uploads/technical_articles/CBIindd-HE-Nov061.pdf.

Spath, P.; Aden, A.; Eggeman, T.; Ringer, M.; Wallace, B.; Jechura, J. (May 2005). *Biomass to Hydrogen Production Detailed Design and Economics Utilizing the Battelle Columbus Laboratory Indirectly-Heated Gasifier*. 161 pp. NREL/TP-510-37408. Golden, CO: National Renewable Energy Laboratory.

Spath, P. L.; Dayton, D. C. (2003). *Preliminary Screening – Technical and Economic Assessment of Synthesis Gas to Fuels and Chemicals with Emphasis on the Potential for Biomass-Derived Syngas*. 160 pp. NREL/TP-510-34929. Golden, CO: National Renewable Energy Laboratory.

SRI. (1999). *Liquid Hydrocarbons from Synthesis Gas*. Process Economics Program Report 191A. Menlo Park, CA: SRI Consulting.

The White House. (5 May 2009). "President Obama Announces Steps to Support Sustainable Energy Options, Departments of Agriculture and Energy, Environmental Protection Agency to Lead Efforts." Washington, DC: The White House Office of the Press Secretary. Available at http://www.whitehouse.gov/the_press_office/President-Obama-Announces-Steps-to-Support-Sustainable-Energy-Options/. Accessed September 1, 2009.

Weast, R.C., ed. (1981). *CRC handbook of Chemistry and Physics*, 62nd edition. Boca Raton, FL: CRC Press.

Twigg, M.V. (1996). *Catalyst Handbook*, London: Manson Pub.

University of Wisconsin-Milwaukee. (2007). Physical Plant Services. "Environmental Survey: Utility Tunnel CW System." <http://www4.uwm.edu/pps/Usaa/ASB/CAMPUS/TUN/cwventing.html>. Accessed November 23, 2010.

Appendix A. List of Acronyms

BCL	Battelle Columbus Laboratory	MeOH	Methanol
BFW	Boiler Feed Water	MMBtu	Million British Thermal Units
bpd	Barrels per Day	MoS₂	Molybdenum Disulfide
BTG	Biomass-to-Gasoline	MTBE	Methyl Tertiary-Butyl Ether
BTU	British Thermal Unit	MTG	Methanol-to-Gasoline
CE	Chemical Engineering Magazine	MW	Megawatts
CFM	Cubic Feet per Minute	MYPP	Biomass Multi-Year Program Plan
CH₄	Methane	MYTP	Biomass Multi-Year Technical Plan
CO	Carbon Monoxide	NPV	Net Present Value
CO₂	Carbon Dioxide	NREL	National Renewable Energy Laboratory
DCFROR	Discounted Cash Flow Rate of Return	NRTL	Non-Random Two Liquid activity coefficient method
DOE	U.S. Department of Energy	OBP	Office of the Biomass Program
DME	Dimethylether	PEP	SRI Consulting Process Economics Program
EDR	Ethanol Design Report (Phillips et al. 2007)	PFD	Process Flow Diagram
EIA	Energy Information Administration	PGP	Plant Gate Price
EtOH	Ethanol	PNNL	Pacific Northwest National Laboratory
FTL	Fischer-Tropsch Liquids	PPMV	Parts Per Million by Volume
FY	Fiscal Year	psia	Pounds per Square Inch (absolute)
GAO	Government Accountability Office	RKS-BM	Redlich-Kwong-Soave equation of state with Boston-Mathius modifications
GHSV	Gas Hourly Space Velocity	RVP	Reid Vapor Pressure
GJ	GigaJoule	SMR	Steam Methane Reformer
gpm	Gallons per Minute	TCPDU	NREL's Thermochemical Process Development Unit
H₂	Hydrogen	TIC	Total Installed Cost
HF	Hydrofluoric (acid)	tpd	Short Tons per Day
HHV	Higher Heating Value	TPI	Total Project Investment
IRR	Internal Rate of Return	WGS	Water Gas Shift
kWh	Kilowatt-hour	WWT	Wastewater Treatment
LHV	Lower Heating Value	ZSM-5	Zeolite Catalyst
LO-CAT	Hydrogen Sulfide Removal Technology		
LPG	Liquefied Petroleum Gas		
LTS	Low Temperature Shift		
MESP	Minimum Ethanol Selling Price		

Appendix B. Comparison of Aspen Model to Four MTG Compositions from Literature

DOE	Mobil - Fluidized Bed	Aspen	KO -	PH - Fixed Bed - 300psi (2.1 MPa)	DOE - Fixed Bed - 300psi (2.1 Mpa)	Mobil - Fluidized Bed - 60psi (413 kPa)	Aspen - 200psi (1.4 MPa)
Coke					0.1		
Acetone					0.5		
Formic Acid					0.5		
Methanol					0.0		
Dimethylether					0.0		
Water					0.0		0.0
Carbon Monoxide					0.0		
Carbon Dioxide					0.2		
Hydrogen					0.0		
Methane	Methane	CH ₄	1.0	1.0	0.8	0.8-0.9	1.0
Ethane	Ethane	C ₂ H ₆	0.6		0.4	0.1-0.25	0.6
Ethene	Ethylene	C ₂ H ₄	0.5		0.0	4.4-6.5	0.5
Propane	Propane	C ₃ H ₈	16.2	5.0	4.6	2.8-3.7	5.2
Propene	Propene	C ₃ H ₆	1.0		0.2	5.4-8.0	1.0
N-Butane	n-Butane	N-C ₄ H ₁₀	5.6	12.0	2.7	0.9-1.5	5.0
I-Butane	Isobutane	I-C ₄ H ₁₀	18.7		8.6	10.8-15.7	7.5
Butenes		BUTENE	1.3	1.0	1.1		1.0
	Dimethylbutanes					1.0-1.2	
N-Pentane	n-Pentane	PENTANE	1.3	14.0	1.4	0.3-0.5	14.5
I-Pentanes	Isopentane		7.8		12.0	10.1-12.4	
Pentenes	Pentenes	PENTENE	0.5	2.0	2.2	2.2-3.1	2.1
Cyclopentane	Cyclopentane				0.2	0.1-0.4	
Methylcyclopentane	Methylcyclopentane		4.3		1.3	0.6-0.7	
	Methylpentanes					5.4-6.0	
N-Hexane	n-Hexane	HEXANE		14.0	0.7	4.1-5.4	14.5
I-Hexanes					12.2		

Hexenes	Hexenes	HEXENE		2.0	1.8	0.3-0.5	2.1
Cyclohexane	Cyclohexane					0.03-0.3	
Methylcyclohexane					0.4		
N-heptane	C7-PON	HEPTANE		6.0	0.2	3.3-4.3	6.2
I-Heptanes					5.6		
Heptenes		HEPTENE		4.0	2.0		4.2
1,3-Dicyclopentane, cis					1.6		
N-Octane	C8-Paraffins, Olefins, Naphthenes	OCTANE		2.0		2.9-3.9	2.1
I-Octanes		I-OCTANE			1.9		
Octenes		OCTENE		5.0	2.4		5.2
N-Propylcyclopentane					2.4		
N-Nonane	C9-Paraffins, Olefins, Naphthenes	NONANE		1.0	0.1	1.6-2.4	2.1
I-Nonanes					0.8		
Nonenes		NONENE		2.0	1.0		2.1
N-Butylcyclopentane					0.6		
I-Decanes	C10-Paraffins, Olefins, Naphthenes				0.2	0.1-0.4	
Decenes					0.4		
Benzene	Benzene	C6H6	1.7		0.2	0.0	1.8
Toluene	Toluene	TOLUENE	10.5	2.0	1.8	1.4-4.0	1.9
Ethylbenzene	Ethylbenzene	ETHBENZ	0.8		0.5	0.16-0.18	1.0
Xylenes, meta+para	Xylenes	XYLENE	17.2	9.0	6.6	5.5-6.3	8.5
O-Xylene					1.8		
1,2,4-Trimethylbenzene	Trimethylbenzenes	124TMB	7.5	10.0	7.0	7.2-8.4	9.5
1,3,5-Trimethylbenzene					0.3		
	Methylethylbenzenes					1.3-1.4	

P-Ethyltoluene					2.5		
I-Propylbenzene	Propylbenzenes				0.1	0.02-0.03	
Naphthalene	Naphthalenes	C10H8	3.3			0.0-1.1	0.0
1,2,4,5-Tetramethylbenzene	1,2,4,5-Tetramethylbenzene	1245TMB		8.0	4.2	1.9-3.4	0.7
1,2,3,5-Tetramethylbenzene	1,2,3,5-Tetramethylbenzene	1235TMB			0.6	1.0-1.8	0.0
1,2,3,4-Tetramethylbenzene	1,2,3,4-Tetramethylbenzene				0.2	0.4-0.6	0.8
P-Diethylbenzene					1.9		
	Other C10 Benzenes					1.0-1.4	
Penta-methylbenzene			0.2		0.7		
	C11 Benzenes					0.3-1.7	
	Other Aromatics					0.7-2.6	
2-Methylnaphthalene					0.2		

The compositions are given in wt %. The sources are the following: KO = Kirk-Othmer Encyclopedia of Chemical Technology (does not specify reactor type or pressure); PH = Probstein and Hicks (1982); DOE = 1978 DOE report (Schreiner 1978); Fluid Bed from Liederman et al. 1978.

Appendix C. NREL Biorefinery Design Database Description and Summary

NREL's Process Engineering Team has developed a database of primary information on all of the equipment in the benchmark model. This database contains information about the cost, reference year, scaling factor, scaling characteristic, design information and back-up cost referencing. The information is stored in a secure database and can be directly linked to the economic portion of the model. In addition to having all of the cost information used by the model, it has the ability to store documents pertaining to the piece of equipment. These include sizing and costing calculations and vendor information when available.

The following summarizes the important fields of information contained in the database. A partial listing of the information is attached for each piece of equipment. Additional information from the database is contained in the equipment cost listing in Appendix D.

Equipment Number: ^{AB}	Unique identifier, the first letter indicates the equipment type and the first number represents the process area, e.g., P-301 is a pump in Area 300
Equipment Name: ^{AB}	Descriptive name of the piece of equipment
Associated PFD:	PFD number on which the piece of equipment appears, e.g., PFD-P800-A101
Equipment Category: ^A	Code indicating the general type of equipment, e.g., PUMP
Equipment Type: ^A	Code indicating the specific type of equipment, e.g., CENTRIFUGAL for a pump
Equipment Description: ^A	Short description of the size or characteristics of the piece of equipment, e.g., 20 gpm, 82 ft head for a pump
Number Required: ^B	Number of duplicate pieces of equipment needed
Number Spares: ^B	Number of on-line spares
Scaling Stream: ^B	Stream number or other characteristic variable from the ASPEN model by which the equipment cost will be scaled
Base Cost: ^B	Equipment cost
Cost Basis: ^A	Source of the equipment cost, e.g., ICARUS or VENDOR
Cost Year: ^B	Year for which the cost estimate is based
Base for Scaling: ^B	Value of the scaling stream or variable used to obtain the base cost of the equipment
Base Type:	Type of variable used for scaling, e.g., FLOW, DUTY, etc.
Base Units:	Units of the scaling stream or variable, e.g., KG/HR, CAL/S
Installation Factor: ^B	Value of the installation factor. Installed Cost = Base Cost x Installation Factor
Installation Factor Basis:	Source of the installation factor value, e.g., ICARUS, VENDOR
Scale Factor Exponent: ^B	Value of the exponential scaling equation
Scale Factor Basis:	Source of the scaling exponent value, e.g., GARRETT, VENDOR
Material of Construction: ^A	Material of Construction
Notes:	Any other important information about the design or cost
Document:	Complete, multi-page document containing design calculations, vendor literature and quotations and any other important information. This is stored as an electronic document and can be pages from a spreadsheet other electronic sources or scanned information from vendors.
Design Date:	Original date for the design of this piece of equipment
Modified Date:	The system automatically marks the date in this field whenever any field is changed

^A These fields are listed for all pieces of equipment in this Appendix.

^B These fields are part of the equipment cost listing in Appendix D.

EQUIPMENT_NUM BER	EQUIPMENT_NAME	EQUIPMENT_ TYPE	MATERIAL_ CONST	COST_ BASIS
PFD-850-A101				
C-101	Hopper Feeder	VIBRATING-FEEDER	CS	LITERATURE
C-102	Screener Feeder Conveyor	BELT	CS	LITERATURE
C-103	Radial Stacker Conveyor	BELT	CS	LITERATURE
M-101	Hydraulic Truck Dump with Scale	TRUCK-SCALE		LITERATURE
M-102	Hammermill		CS	LITERATURE
M-103	Front End Loaders	LOADER	CS	LITERATURE
S-101	Magnetic Head Pulley	MAGNET	CS	LITERATURE
S-102	Screener	SCREEN	CS	LITERATURE
T-101	Dump Hopper	LIVE-BTM-BIN	CS	LITERATURE
T-102	Hammermill Surge Bin	LIVE-BTM-BIN	CS	LITERATURE
T-103	Dryer Feed Bin	LIVE-BTM-BIN	CS	LITERATURE

PFD-850-A102

C-104	Dryer Feed Screw Conveyor	SCREW	CS	LITERATURE
C-105	Gasifier Feed Screw Conveyor	SCREW	316SS	LITERATURE
K-101	Flue Gas Blower	CENTRIFUGAL	SS304	LITERATURE
M-104	Rotary Biomass Dryer	ROTARY-DRUM	CS	LITERATURE
S-103	Dryer Air Cyclone	GAS CYCLONE	CS	LITERATURE
S-104	Dryer Air Baghouse Filter	FABRIC-FILTER		LITERATURE
T-104	Dried Biomass Hopper	VERTICAL-VESSEL	CS	LITERATURE

PFD-850-A201

C-201	Sand/ash Conditioner/Conveyor	SCREW	CS	LITERATURE
H-209A	Pinch HX System	DHE FIXED T S		IPE
H-209B	Pinch HX System	DHE U TUBE		IPE
H-209C	Pinch HX System	DHE U TUBE		IPE
K-202	Combustion Air Blower	CENTRIFUGAL	CS	LITERATURE
M-201	Sand/ash Cooler	MISCELLANEOUS		LITERATURE
R-201	Indirectly-heated Biomass Gasifier	VERTICAL-VESSEL	CS w/refractory	LITERATURE
R-202	Char Combustor	VERTICAL-VESSEL	CS w/refractory	LITERATURE
S-201	Primary Gasifier Cyclone	GAS CYCLONE	CS w/refractory	LITERATURE
S-202	Secondary Gasifier Cyclone	GAS CYCLONE	CS w/refractory	LITERATURE
S-203	Primary Combustor Cyclone	GAS CYCLONE	CS w/refractory	LITERATURE
S-204	Secondary Combustor Cyclone	GAS CYCLONE	CS w/refractory	LITERATURE
S-205	Electrostatic Precipitator	MISCELLANEOUS	CS	LITERATURE
T-201	Sand/ash Bin	FLAT-BTM-STORAGE	CS	LITERATURE

PFD-P850-A301

H-301A	Post-Reformer Cooler #1	SHELL-TUBE		IPE
H-315D	Pinch HX System	EHE JACKETED		IPE
H-315DB	Pinch HX System	DHE FIXED T S		IPE
H-330A	Pinch HX System	DHE FIXED T S		IPE
H-330B	Pinch HX System	DHE FIXED T S		IPE
H-330C	Pinch HX System	DHE FIXED T S		IPE
H-330D	Pinch HX System	DHE FIXED T S		IPE
K-305	Regenerator Combustion Air Blower	CENTRIFUGAL	SS304	QUESTIMATE
R-301A	Tar Reformer Catalyst Regenerator	VERTICAL-VESSEL	CS w/refractory	LITERATURE
R-303	Tar Reformer	VERTICAL-VESSEL	CS w/refractory	LITERATURE
S-306	Tar Reformer Cyclone	GAS CYCLONE	CS	LITERATURE
S-307	Catalyst Regenerator Cyclone	GAS CYCLONE	CS	LITERATURE

PFD-P850-A302

H-301B	Post-Reformer Cooler #2	AIR-COOLED EXCHANGER	A214	IPE
M-301	Syngas Quench Chamber		CS	LITERATURE
M-302	Syngas Venturi Scrubber		CS	LITERATURE
P-301	Sludge Pump	CENTRIFUGAL	CS	QUESTIMATE
P-302	Quench Water Recirculation Pump	CENTRIFUGAL	CS	LITERATURE
T-301	Sludge Settling Tank	CLARIFIER	SS304	QUESTIMATE
T-302	Quench Water Recirculation Tank	HORIZONTAL-VESSEL	CS	LITERATURE

PFD-P850-A303

H-302	Syngas Compressor Intercoolers	AIR-COOLED EXCHANGER	CS	ICARUS
H-303	Water-cooled Aftercooler	SHELL-TUBE	SS304CS/A2 14	QUESTIMATE
K-301	Syngas Compressor	CENTRIFUGAL	A285C	QUESTIMATE
S-301	Pre-compressor Knock-out	KNOCK-OUT DRUM	CS	QUESTIMATE
S-302	Syngas Compressor Interstage Knock-outs	KNOCK-OUT DRUM	CS	ICARUS
S-303	Post-compressor Knock-out	KNOCK-OUT DRUM	CS	QUESTIMATE

PFD-P850-A304

S-310	L.P. Amine System	ABSORBER		OTHER
-------	-------------------	----------	--	-------

PFD-P850-A305

H-304	LO-CAT Preheater	SHELL-TUBE	A285C/CA44 3	QUESTIMATE
H-305	LO-CAT Absorbent Solution Cooler	SHELL-TUBE	304SS	VENDOR
K-302	LO-CAT Feed Air Blower	CENTRIFUGAL	CS	VENDOR
M-303	LO-CAT Venturi Precontactor		304SS	VENDOR
M-304	LO-CAT Liquid-filled Absorber	ABSORBER	304SS	VENDOR

P-303	LO-CAT Absorbent Solution Circulating Pump	CENTRIFUGAL	304SS	VENDOR
R-304	LO-CAT Oxidizer Vessel	VERTICAL-VESSEL	304SS	VENDOR

PFD-P850-A401

R-434	Low Temperature Shift Reactor	VERTICAL-VESSEL	CS w/refractory	QUESTIMATE
-------	-------------------------------	-----------------	--------------------	------------

PFD-P850-A402

H-301C	Reformed Syngas cooler / Synthesis Reactor Preheat #1	SHELL-TUBE	A214	QUESTIMATE
H-416A	Pinch HX System	DHE U TUBE		IPE
H-416B	Pinch HX System	DHE U TUBE		IPE
K-412	Purge Gas Expander	CENTRIFUGAL	A285C	QUESTIMATE
K-414	Unreacted Syngas Recycle Compressor	CENTRIFUGAL	A285C	QUESTIMATE
S-414	Methanol Flash Drum	HORIZONTAL-VESSEL	CS	QUESTIMATE

PFD-P850-A403

H-410A	Pinch HX System	DHE U TUBE		IPE
H-410C	Pinch HX System	DHE U TUBE		IPE
H-410D	Pinch HX System	DHE U TUBE		IPE
H-410E	Pinch HX System	DHE U TUBE		IPE
H-410F	Pinch HX System	DHE U TUBE		IPE
H-410G	Pinch HX System	DHE U TUBE		IPE
H-411	post Reactor Syngas cooling #2	SHELL-TUBE	A285C/CA44 3	IPE
H-411B	post Reactor Syngas cooling #3 - Air Cooled	AIR-COOLED EXCHANGER	A214	QUESTIMATE
H-413	post Reactor Syngas cooling #3 - Air Cooled	SHELL-TUBE	CS/A214	QUESTIMATE
H-414	Methanol Condenser	SHELL-TUBE	A214	QUESTIMATE
R-490	High pressure Synthesis Reactor	VERTICAL-VESSEL	CS w/refractory	QUESTIMATE

PFD-P850-A502

D-500	Methanol Degassing Column	DISTILLATION	SS305	ICARUS
H-500R	Methanol Column Reboiler	SHELL-TUBE	SS304;CS	ICARUS
H-504B	Cooler	SHELL-TUBE	A214	QUESTIMATE
H-505A	Pinch HX System	DHE U TUBE		IPE
H-505B	Pinch HX System	DHE U TUBE		IPE
H-505C	Pinch HX System	DHE U TUBE		IPE
H-505D	Pinch HX System	DHE U TUBE		IPE
H-593	METHANOL Product Finishing cooler	SHELL-TUBE	CS	LITERATURE
K-501	Methanol Gas Expander	CENTRIFUGAL	A285C	QUESTIMATE
P-500B	Deaerator Feed Pump	CENTRIFUGAL	CS	QUESTIMATE
P-500R	Deaerator Feed Pump	CENTRIFUGAL	CS	QUESTIMATE
P-592	Methanol Product Pump	CENTRIFUGAL	CS	ICARUS

PFD-P850-A601

H-605A	Pinch HX System	DHE FIXED T S		IPE
H-605B	Pinch HX System	DHE FIXED T S		IPE
H-605C	Pinch HX System	DHE FIXED T S		IPE
H-605D	Pinch HX System	DHE U TUBE		IPE
H-605E	Pinch HX System	DHE U TUBE		IPE
H-605F	Pinch HX System	DHE U TUBE		IPE
H-630A	Pinch HX System	DHE FIXED T S		IPE
H-630B	Pinch HX System	DHE U TUBE		IPE
H-642	Pinch HX System	EHE JACKETED		IPE
M-601	Hot Process Water Softener System	PACKAGE		RICHARDSON
P-603	Deaerator Feed Pump	CENTRIFUGAL	CS	QUESTIMATE
P-604	Boiler Feed Water Pump	CENTRIFUGAL	CS	QUESTIMATE
T-601	Condensate Collection Tank	HORIZONTAL-VESSEL	CS	QUESTIMATE
T-602	Condensate Surge Drum	HORIZONTAL-VESSEL	CS	QUESTIMATE
T-603	Deaerator	HORIZONTAL-VESSEL	CS;SS316	VENDOR

PFD-P850-A602

H-200A	Pinch HX System	EHE JACKETED		IPE
H-200B	Pinch HX System	DHE PRE ENGR		IPE
H-601	Steam Turbine Condenser	SHELL-TUBE		ADEN, ET. AL. 2002
H-620	Pinch HX System	DHE FIXED T S		IPE
M-602	Extraction Steam Turbine/Generator	STEAM-TURBINE		VENDOR
P-601	Collection Pump	CENTRIFUGAL	CS	QUESTIMATE
P-602	Condensate Pump	CENTRIFUGAL	SS304	QUESTIMATE

PFD-P850-A603

H-603	Blowdown Water-cooled Cooler	SHELL-TUBE	A214	QUESTIMATE
H-607	Pinch HX System	DHE FIXED T S		IPE
S-601	Blowdown Flash Drum	HORIZONTAL-VESSEL	CS	QUESTIMATE
T-604	Steam Drum	HORIZONTAL-VESSEL	CS	ICARUS

PFD-P850-A701

K-701	Plant Air Compressor	RECIPROCATING	CS	ICARUS
M-701	Cooling Tower System	INDUCED-DRAFT	FIBERGLAS S	DELTA-T98
P-701	Cooling Water Pump	CENTRIFUGAL	CS	QUESTIMATE
S-701	Instrument Air Dryer	PACKAGE	CS	RICHARDSON
T-701	Plant Air Receiver	HORIZONTAL-VESSEL	CS	ICARUS

PFD-P850-A702

M-702	Hydraulic Truck Dump with Scale	TRUCK-SCALE	CS	VENDOR
P-702	Firewater Pump	CENTRIFUGAL	CS	ICARUS
P-703	Diesel Pump	CENTRIFUGAL	CS	ICARUS
P-704	Ammonia Pump	CENTRIFUGAL	CS	ICARUS
P-705	Hydrazine Pump	CENTRIFUGAL	CS	DELTA-T98
T-702	Firewater Storage Tank	FLAT-BTM-STORAGE	A285C	ICARUS
T-703	Diesel Storage Tank	FLAT-BTM-STORAGE	A285C	ICARUS
T-704	Ammonia Storage Tank	HORIZONTAL-STORAGE	A515	ICARUS
T-705	Olivine Lock Hopper	VERTICAL-VESSEL	CS	DELTA-T98
T-706	MgO Lock Hopper	VERTICAL-VESSEL	CS	DELTA-T98
T-707	Hydrazine Storage Tank	VERTICAL-VESSEL	SS316	ICARUS

PFD-P850-A1401

H-1401A	Pinch HX System	DHE FIXED T S		IPE
H-1401B	Pinch HX System	DHE FIXED T S		IPE
H-1401C	Pinch HX System	DHE FIXED T S		IPE
H-1410	Pinch HX System	DHE FIXED T S		IPE
P-1000	Methanol Intermediate Pump	CENTRIFUGAL	CS	ICARUS
R-1410	MTG Reactor	VERTICAL-VESSEL		
T-592	Methanol Product Storage Tank	FLAT-BTM-STORAGE	A285C	ICARUS

PFD-P850-A1402

H-315A	Pinch HX System	EHE JACKETED		IPE
H-1411B	Pinch HX System	DHE FIXED T S		IPE
H-1413	post MTG Reactor #3 Air Cooled	SHELL-TUBE	A285C/CA44 5	QUESTIMATE
H-1414	post MTG Reactor #4 water cooled	SHELL-TUBE	A285C/CA44 6	QUESTIMATE
H-1416	Pinch HX System	DHE FIXED T S		IPE
S-1401	Mixed HC Condensation Knock-out	KNOCK-OUT DRUM	A-515	QUESTIMATE

PFD-P850-A1501

D-1502	Absorber Column	DISTILLATION		IPE
D-1503	Deethanizer Column	DISTILLATION		IPE
H-1503R	De-ethanizer Column Reboiler	SHELL-TUBE	SS304;CS	ICARUS
H-1506A	Pinch HX System	DHE FIXED T S		IPE
H-1506B	Pinch HX System	DHE FIXED T S		IPE
H-1506C	Pinch HX System	DHE FIXED T S		IPE
H-1506D	Pinch HX System	DHE FIXED T S		IPE
H-1508	D1503 Reflux Heater	SHELL-TUBE	A214	QUESTIMATE
H-1512B	Lean Oil Recycle Cooler #2	SHELL-TUBE	SS304CS/A2 14	QUESTIMATE
P-1503	Crude Hydrocarbons Pump	CENTRIFUGAL	CS	ICARUS

P-1503B	D1503 Reboiler Pump	CENTRIFUGAL	CS	ICARUS
P-1508	D1503 Reflux Pump	CENTRIFUGAL	CS	ICARUS

PFD-P850-A1502

D-1504	Stabilizer Column	DISTILLATION		IPE
D-1505	Splitter Column	DISTILLATION		IPE
D-1506	LPG/ Alkylate Splitter	DISTILLATION		IPE
H-1504R	Stabilizer Column Reboiler	SHELL-TUBE	SS304;CS	ICARUS
H-1504C	Stabilizer Column Condenser	SHELL-TUBE	A214	QUESTIMATE
H-1505R	Splitter Column Reboiler	SHELL-TUBE	SS304;CS	ICARUS
H-1505	Pinch HX System	DHE FIXED T S		IPE
H-1505B	Pinch HX System	DHE FIXED T S		IPE
P-1504B	D1504 Reboiler Pump	CENTRIFUGAL	CS	ICARUS
P-1505B	D1505 Reboiler Pump	CENTRIFUGAL	CS	ICARUS
R-1505	HF Alkylation Unit		CS w/refractory	ICARUS

PFD-P850-A1503

H-1591	LPG product cooler - cw	SHELL-TUBE	A214	IPE
H-1593	Gasoline product cooler - cw	SHELL-TUBE	A214	IPE
P-1590	LPG Product Pump	CENTRIFUGAL	CS	ICARUS
P-1592	Gasoline Product Pump	CENTRIFUGAL	CS	ICARUS
T-1590	LPG Product Storage Tank	FLAT-BTM-STORAGE	A285C	ICARUS
T-1592	Gasoline Product Storage Tank	FLAT-BTM-STORAGE	A285C	ICARUS

Appendix D. Individual Equipment Cost Summary

Equipment Number	Number Required	Number Spares	Equipment Name	Size Ratio	Original Equip Cost (per unit)	Base Year	Total Original Equip Cost (Req'd & Spare) in Base Year	Scaling Exponent	Scaled Cost in Base Year	Installation Factor	Installed Cost in Base Year	Installed Cost in \$2007
C-101	4		Hopper Feeder	1.00	\$0	2002	\$0	0.75	\$0	2.47	\$0	\$0
C-102	2		Screening Feeder Conveyor	1.00	\$0	2002	\$0	0.75	\$0	2.47	\$0	\$0
C-103	2		Radial Stacker Conveyor	1.00	\$0	2002	\$0	0.75	\$0	2.47	\$0	\$0
C-104	2		Dryer Feed Screw Conveyor	1.00	\$0	2002	\$0	0.75	\$0	2.47	\$0	\$0
C-105	2		Gasifier Feed Screw Conveyor	0.98	\$0	2002	\$0	0.75	\$0	2.47	\$0	\$0
K-101	2		Flue Gas Blower	1.60	\$0	2002	\$0	0.75	\$0	2.47	\$0	\$0
M-101	4		Hydraulic Truck Dump with Scale	1.00	\$0	2002	\$0	0.75	\$0	2.47	\$0	\$0
M-102	2		Hammermill	1.00	\$0	2002	\$0	0.75	\$0	2.47	\$0	\$0
M-103	3		Front End Loaders	1.00	\$0	2002	\$0	0.75	\$0	2.47	\$0	\$0
M-104	2		Rotary Biomass Dryer	1.00	\$3,813,728	2002	\$7,627,455	0.75	\$7,627,450	2.47	\$18,839,801	\$25,021,313
S-101	2		Magnetic Head Pulley	1.00	\$0	2002	\$0	0.75	\$0	2.47	\$0	\$0
S-102	2		Screening	1.00	\$0	2002	\$0	0.75	\$0	2.47	\$0	\$0
S-103	2		Dryer Air Cyclone	1.60	\$0	2002	\$0	0.75	\$0	2.47	\$0	\$0
S-104	2		Dryer Air Baghouse Filter	0.98	\$0	2002	\$0	0.75	\$0	2.47	\$0	\$0
T-101	4		Dump Hopper	1.00	\$0	2002	\$0	0.75	\$0	2.47	\$0	\$0
T-102	1		Hammermill Surge Bin	1.00	\$0	2002	\$0	0.75	\$0	2.47	\$0	\$0
T-103	2		Dryer Feed Bin	1.00	\$0	2002	\$0	0.75	\$0	2.47	\$0	\$0
T-104	2		Dried Biomass Hopper	0.98	\$0	2002	\$0	0.75	\$0	2.47	\$0	\$0

A100				Subtotal	\$7,627,455		\$7,627,450	2.47	\$18,839,801	\$25,021,313	
C-201	1	Sand/ash Conditioner/Conveyor	0.33	\$0	2002	\$0	0.65	\$0	2.47	\$0	\$0
K-202	2	Combustion Air Blower	1.01	\$0	2002	\$0	0.65	\$0	2.47	\$0	\$0
M-201	2	Sand/ash Cooler	0.33	\$0	2002	\$0	0.65	\$0	2.47	\$0	\$0
R-201	2	Indirectly-heated Biomass Gasifier	1.01	\$2,212,201	2002	\$4,424,402	0.65	\$4,451,012	2.47	\$10,994,000	\$14,601,232
R-202	2	Char Combustor	1.01	\$0	2002	\$0	0.65	\$0	2.47	\$0	\$0
S-201	2	Primary Gasifier Cyclone	1.01	\$0	2002	\$0	0.65	\$0	2.47	\$0	\$0
S-202	2	Secondary Gasifier Cyclone	1.00	\$0	2002	\$0	0.65	\$0	2.47	\$0	\$0
S-203	2	Primary Combustor Cyclone	1.01	\$0	2002	\$0	0.65	\$0	2.47	\$0	\$0
S-204	2	Secondary Combustor Cyclone	0.99	\$0	2002	\$0	0.65	\$0	2.47	\$0	\$0
S-205	2	Electrostatic Precipitator	1.00	\$0	2002	\$0	0.65	\$0	2.47	\$0	\$0
T-201	1	Sand/ash Bin	0.33	\$0	2002	\$0	0.65	\$0	2.47	\$0	\$0
H-200A	1	Pinch HX System		\$10,600	2007	\$10,600	0.6	\$10,600	2.47	\$26,182	\$26,182
H-200B	1	Pinch HX System		\$1,800	2007	\$1,800	0.6	\$1,800	2.47	\$4,446	\$4,446
H-209A	1	Pinch HX System		\$30,600	2007	\$30,600	0.6	\$30,600	2.47	\$75,582	\$75,582
H-209B	1	Pinch HX System		\$38,200	2007	\$38,200	0.6	\$38,200	2.47	\$94,354	\$94,354
H-209C	1	Pinch HX System		\$54,600	2007	\$54,600	0.6	\$54,600	2.47	\$134,862	\$134,862
A200				Subtotal	\$4,424,402		\$4,451,012	2.47	\$10,994,000	\$14,601,232	
H-301A	1	Pinch HX System		\$98,200	2007	\$98,200	0.6	\$98,200	2.47	\$242,554	\$242,554
H-301B	1	Post-Reformer Cooler #2	0.90	\$50,300	2007	\$50,300	0.6	\$47,357	2.47	\$116,973	\$116,973
H-301C	1	Pinch HX System		\$22,400	2007	\$22,400	0.6	\$22,400	2.47	\$55,328	\$55,328
H-302	5	Syngas Compressor Intercoolers	0.84	\$0	2002	\$0	0.65	\$0	2.47	\$0	\$0
H-303	1	Water-cooled Aftercooler	0.00	\$20,889	2002	\$20,889	0.44	\$0	2.47	\$0	\$0
H-304	1	LO-CAT Preheater	0.18	\$4,743	2002	\$4,743	0.6	\$1,677	2.47	\$4,142	\$5,500

H-305	1		LO-CAT Absorbent Solution Cooler	0.34	\$0	2002	\$0	0.44	\$0	2.47	\$0	\$0
H-315A	1		Pinch HX System		\$5,400	2007	\$5,400	0.6	\$5,400	2.47	\$13,338	\$13,338
H-315D	1		Pinch HX System		\$83,700	2007	\$83,700	0.6	\$83,700	2.47	\$206,739	\$206,739
H-315DB	1		Pinch HX System		\$17,600	2007	\$17,600	0.6	\$17,600	2.47	\$43,472	\$43,472
H-330A	1		Pinch HX System		\$18,900	2007	\$18,900	0.6	\$18,900	2.47	\$46,683	\$46,683
H-330B	1		Pinch HX System		\$17,500	2007	\$17,500	0.6	\$17,500	2.47	\$43,225	\$43,225
H-330C	1		Pinch HX System		\$35,800	2007	\$35,800	0.6	\$35,800	2.47	\$88,426	\$88,426
H-330D	1		Pinch HX System		\$40,700	2007	\$40,700	0.6	\$40,700	2.47	\$100,529	\$100,529
K-301	1		Syngas Compressor	0.92	\$3,896,834	2002	\$3,896,834	0.8	\$3,652,085	2.47	\$9,020,650	\$11,980,408
K-302	1		LO-CAT Feed Air Blower	0.78	\$0	2002	\$0	0.65	\$0	2.47	\$0	\$0
K-305	1		Regenerator Combustion Air Blower	1.03	\$35,020	2002	\$35,020	0.59	\$35,651	2.47	\$88,058	\$116,951
M-301	1		Syngas Quench Chamber	0.86	\$0	2002	\$0	0.65	\$0	2.47	\$0	\$0
M-302	1		Syngas Venturi Scrubber	0.86	\$0	2002	\$0	0.65	\$0	2.47	\$0	\$0
M-303	1		LO-CAT Venturi Precontactor	0.78	\$0	2002	\$0	0.65	\$0	2.47	\$0	\$0
M-304	1		LO-CAT Liquid-filled Absorber	0.34	\$0	2002	\$0	0.65	\$0	2.47	\$0	\$0
P-301	1	1	Sludge Pump	0.08	\$3,911	2002	\$7,822	0.33	\$3,435	2.47	\$8,484	\$11,268
P-302	1	1	Quench Water Recirculation Pump	0.27	\$0	2002	\$0	0.65	\$0	2.47	\$0	\$0
P-303	1	1	LO-CAT Absorbent Solution Circulating Pump	0.86	\$0	2002	\$0	0.65	\$0	2.47	\$0	\$0
R-301A	1		Tar Reformer Catalyst Regenerator	0.89	\$2,429,379	2002	\$2,429,379	0.65	\$2,253,216	2.47	\$5,565,444	\$7,391,518
R-303	1		Tar Reformer	0.86	\$2,212,201	2002	\$2,212,201	0.65	\$2,009,880	2.47	\$4,964,405	\$6,593,272
R-304	1		LO-CAT Oxidizer Vessel	0.78	\$1,000,000	2002	\$1,000,000	0.65	\$851,685	2.47	\$2,103,663	\$2,793,894
S-301	1		Pre-compressor Knock-out	0.92	\$157,277	2002	\$157,277	0.6	\$149,809	2.47	\$370,027	\$491,437
S-302	4		Syngas Compressor Interstage Knock-outs	0.92	\$0	2002	\$0	0.6	\$0	2.47	\$0	\$0

S-303	1	Post-compressor Knock-out	0.00	\$40,244	2002	\$40,244	0.6	\$0	2.47	\$0	\$0
S-306	1	Tar Reformer Cyclone	0.86	\$0	2002	\$0	0.65	\$0	2.47	\$0	\$0
S-307	1	Catalyst Regenerator Cyclone	0.89	\$0	2002	\$0	0.65	\$0	2.47	\$0	\$0
S-310	1	L.P. Amine System	0.77	\$3,485,685	2002	\$3,485,685	0.75	\$2,866,983	2.47	\$7,081,449	\$9,404,938
T-301	1	Sludge Settling Tank	0.49	\$11,677	2002	\$11,677	0.6	\$7,573	2.47	\$18,706	\$24,844
T-302	1	Quench Water Recirculation Tank	0.86	\$0	2002	\$0	0.65	\$0	2.47	\$0	\$0

A300					Subtotal	\$13,594,071		\$12,121,353	2.47	\$29,939,741	\$39,528,742
-------------	--	--	--	--	-----------------	---------------------	--	---------------------	-------------	---------------------	---------------------

H-410A	1	Pinch HX System		\$25,000	2007	\$25,000	0.6	\$25,000	2.47	\$61,750	\$61,750
H-410C	1	Pinch HX System		\$123,700	2007	\$123,700	0.6	\$123,700	2.47	\$305,539	\$305,539
H-410D	1	Pinch HX System		\$28,300	2007	\$28,300	0.6	\$28,300	2.47	\$69,901	\$69,901
H-410E	1	Pinch HX System		\$85,100	2007	\$85,100	0.6	\$85,100	2.47	\$210,197	\$210,197
H-410G	1	Pinch HX System		\$16,200	2007	\$16,200	0.6	\$16,200	2.47	\$40,014	\$40,014
H-410F	1	Pinch HX System		\$21,800	2007	\$21,800	0.6	\$21,800	2.47	\$53,846	\$53,846
H-411	1	Pinch HX System		\$212,000	2007	\$212,000	0.6	\$212,000	2.47	\$523,640	\$523,640
H-411B	1	post Reactor Syngas cooling #3 - Air Cooled	0.17	\$388,064	2002	\$388,064	0.6	\$135,869	2.47	\$335,597	\$445,709
H-413	1	post Reactor Syngas cooling #3 - Air Cooled	0.01	\$71,389	2002	\$71,389	0.44	\$8,338	2.47	\$20,595	\$27,352
H-414	1	Methanol Condenser	0.14	\$338,016	2002	\$338,016	0.44	\$140,431	2.47	\$346,866	\$460,676
H-416A	1	Pinch HX System		\$16,200	2007	\$16,200	0.6	\$16,200	2.47	\$40,014	\$40,014
H-416B	1	Pinch HX System		\$17,900	2007	\$17,900	0.6	\$17,900	2.47	\$44,213	\$44,213
K-412	1	Purge Gas Expander	1.72	\$642,014	2002	\$642,014	0.8	\$991,770	2.47	\$2,449,673	\$3,253,433
K-414	1	Unreacted Syngas Recycle Compressor	3.34	\$403,122	2002	\$403,122	0.8	\$1,057,398	2.47	\$2,611,772	\$3,468,718
R-434	1	Low Temperature Shift Reactor	0.00	\$4,965,833	2002	\$4,965,833	0.7	\$16,442	2.47	\$40,612	\$53,937
R-490	1	High pressure Synthesis Reactor	0.17	\$2,026,515	2002	\$2,026,515	0.56	\$743,768	2.47	\$1,837,106	\$2,439,877
S-414	1	Methanol Flash Drum	29.95	\$14,977	2002	\$14,977	0.6	\$115,147	2.47	\$284,412	

S-471	1	Methanol Condensation Knock-out	2.04	\$55,447	2002	\$55,447	0.6	\$84,962	2.47	\$209,856	\$278,712
-------	---	------------------------------------	------	----------	------	----------	-----	----------	------	-----------	-----------

A400					Subtotal	\$8,939,477		\$3,328,225	2.47	\$8,220,716	\$10,512,643
-------------	--	--	--	--	-----------------	--------------------	--	--------------------	------	--------------------	---------------------

D-500	1	Methanol Degassing Column	0.11	\$478,100	1998	\$478,100	0.68	\$104,412	2.47	\$257,898	\$347,881
H-500R	1	Methanol Column Reboiler	1.27	\$29,600	1997	\$29,600	0.68	\$34,861	2.47	\$86,107	\$117,052
H-504B	1	Cooler	0.16	\$338,016	2002	\$338,016	0.44	\$151,190	2.47	\$373,439	\$495,968
H-592	1	METHANOL Product Cooler	1.00	\$3,043	2002	\$3,043	0.6	\$3,043	2.47	\$7,516	\$9,982
H-505A	1	Pinch HX System	1.00	\$20,300	2007	\$20,300	0.6	\$20,300	2.47	\$50,141	\$50,141
H-505B	1	Pinch HX System	1.00	\$54,300	2007	\$54,300	0.6	\$54,300	2.47	\$134,121	\$134,121
H-505C	1	Pinch HX System	1.00	\$61,600	2007	\$61,600	0.6	\$61,600	2.47	\$152,152	\$152,152
H-505D	1	Pinch HX System	1.00	\$27,800	2007	\$27,800	0.6	\$27,800	2.47	\$68,666	\$68,666
H-592B	1	Pinch HX System	1.00	\$20,300	2007	\$20,300	0.6	\$20,300	2.47	\$50,141	\$50,141
H-593	1	METHANOL Product Finishing cooler	1.63	\$0	2002	\$0	0.44	\$0	2.47	\$0	\$0
K-501	1	Methanol Gas Expander	1.27	\$642,014	2002	\$642,014	0.8	\$775,537	2.47	\$1,915,575	\$2,544,093
P-500B	1	1 D-500 Bottoms Pump	0.01	\$8,679	2002	\$17,358	0.33	\$3,036	2.47	\$7,499	\$9,959
P-500R	1	1 D-500 Reflux Pump	0.01	\$8,679	2002	\$17,358	0.33	\$3,428	2.47	\$8,467	\$11,246
P-592	1	Methanol Product Pump	2.07	\$7,500	1997	\$7,500	0.79	\$13,348	2.47	\$32,971	\$44,820
T-592	1	Methanol Product Storage Tank	2.07	\$165,800	1997	\$165,800	0.51	\$240,556	2.47	\$594,172	\$807,705

A500					Subtotal	\$1,883,089		\$1,513,711	2.47	\$3,738,866	\$4,843,928
-------------	--	--	--	--	-----------------	--------------------	--	--------------------	------	--------------------	--------------------

H-601	1	Steam Turbine Condenser	1.39	\$0	2002	\$0	0.71	\$0	2.47	\$0	\$0
H-603	1	Blowdown Water-cooled Cooler	0.00	\$16,143	2002	\$16,143	0.44	\$0	2.47	\$0	\$0
H-605A	1	Pinch HX System		\$18,200	2007	\$18,200	0.6	\$18,200	2.47	\$44,954	\$44,954
H-605B	1	Pinch HX System		\$379,900	2007	\$379,900	0.6	\$379,900	2.47	\$938,353	\$938,353
H-605C	1	Pinch HX System		\$36,300	2007	\$36,300	0.6	\$36,300	2.47	\$89,661	\$89,661

H-605D	1		Pinch HX System		\$31,100	2007	\$31,100	0.6	\$31,100	2.47	\$76,817	\$76,817
H-605E	1		Pinch HX System		\$76,400	2007	\$76,400	0.6	\$76,400	2.47	\$188,708	\$188,708
H-605F	1		Pinch HX System		\$25,400	2007	\$25,400	0.6	\$25,400	2.47	\$62,738	\$62,738
H-607	1		Pinch HX System		\$36,400	2007	\$36,400	0.6	\$36,400	2.47	\$89,908	\$89,908
H-620	1		Pinch HX System		\$20,400	2007	\$20,400	0.6	\$20,400	2.47	\$50,388	\$50,388
H-630A	1		Pinch HX System		\$28,200	2007	\$28,200	0.6	\$28,200	2.47	\$69,654	\$69,654
H-630B	1		Pinch HX System		\$16,200	2007	\$16,200	0.6	\$16,200	2.47	\$40,014	\$40,014
H-642	1		Pinch HX System		\$10,900	2007	\$10,900	0.6	\$10,900	2.47	\$26,923	\$26,923
M-601	1		Hot Process Water Softener System	1.20	\$1,031,023	1999	\$1,031,023	0.82	\$1,197,991	2.47	\$2,959,037	\$3,980,230
M-602	1		Extraction Steam Turbine/Generator	1.20	\$4,045,870	2002	\$4,045,870	0.71	\$4,599,565	2.47	\$11,360,926	\$15,088,550
M-603	1		Startup Boiler	1.00	\$198,351	2002	\$198,351	0.6	\$198,351	2.47	\$489,927	\$650,676
P-601	1	1	Collection Pump	0.39	\$7,015	2002	\$14,030	0.33	\$10,310	2.47	\$25,465	\$33,821
P-602	1	1	Condensate Pump	1.39	\$5,437	2002	\$10,874	0.33	\$12,116	2.47	\$29,927	\$39,747
P-603	1	1	Deaerator Feed Pump	1.20	\$8,679	2002	\$17,358	0.33	\$18,439	2.47	\$45,544	\$60,487
P-604	1	1	Boiler Feed Water Pump	1.20	\$95,660	2002	\$191,320	0.33	\$203,233	2.47	\$501,985	\$666,691
T-601	1		Condensate Collection Tank	1.20	\$24,493	2002	\$24,493	0.6	\$27,336	2.47	\$67,520	\$89,675
T-602	1		Condensate Surge Drum	1.20	\$28,572	2002	\$28,572	0.6	\$31,889	2.47	\$78,765	\$104,609
T-603	1		Deaerator	1.20	\$130,721	2002	\$130,721	0.72	\$149,135	2.47	\$368,365	\$489,228
T-604	1		Steam Drum	1.20	\$9,200	1997	\$9,200	0.72	\$10,478	2.47	\$25,881	\$35,182
S-601	1		Blowdown Flash Drum	1.20	\$14,977	2002	\$14,977	0.6	\$16,692	2.47	\$41,229	\$54,757

A600						Subtotal	\$6,412,332		\$7,154,934	2.47	\$17,672,688	\$22,971,769
-------------	--	--	--	--	--	-----------------	--------------------	--	--------------------	-------------	---------------------	---------------------

K-701	2	1	Plant Air Compressor	1.00	\$32,376	2002	\$97,129	0.34	\$97,129	2.47	\$239,908	\$318,624
M-701	1		Cooling Tower System	0.00	\$267,316	2002	\$267,316	0.78	\$0	2.47	\$0	\$0
M-702	1		Hydraulic Truck Dump with Scale	1.00	\$80,000	1998	\$80,000	0.6	\$80,000	2.47	\$197,600	\$266,544
M-703	1		Flue Gas Stack	0.32	\$51,581	2002	\$51,581	1	\$16,705	2.47	\$41,262	\$54,801
P-701	1	1	Cooling Water Pump	1.33	\$158,540	2002	\$317,080	0.33	\$348,290	2.47	\$860,276	\$1,142,541
P-702	1	1	Firewater Pump	1.00	\$18,400	1997	\$36,800	0.79	\$36,800	2.47	\$90,896	\$123,562
P-703	1	1	Diesel Pump	1.00	\$6,100	1997	\$12,200	0.79	\$12,200	2.47	\$30,134	\$40,963

P-704	1	1	Ammonia Pump	1.00	\$5,000	1997	\$10,000	0.79	\$10,000	2.47	\$24,700	\$33,577
P-705	1		Hydrazine Pump	1.00	\$5,500	1997	\$5,500	0.79	\$5,500	2.47	\$13,585	\$18,467
S-701	1	1	Instrument Air Dryer	1.00	\$8,349	2002	\$16,698	0.6	\$16,698	2.47	\$41,244	\$54,777
T-701	1		Plant Air Receiver	1.00	\$7,003	2002	\$7,003	0.72	\$7,003	2.47	\$17,297	\$22,973
T-702	1		Firewater Storage Tank	1.00	\$166,100	1997	\$166,100	0.51	\$166,100	2.47	\$410,267	\$557,708
T-703	1		Diesel Storage Tank	1.00	\$14,400	1997	\$14,400	0.51	\$14,400	2.47	\$35,568	\$48,350
T-704	1		Ammonia Storage Tank	1.00	\$287,300	1997	\$287,300	0.72	\$287,300	2.47	\$709,631	\$964,657
T-705	1		Olivine Lock Hopper	1.00	\$0	1998	\$0	0.71	\$0	2.47	\$0	\$0
T-706	1		MgO Lock Hopper	1.00	\$0	1998	\$0	0.71	\$0	2.47	\$0	\$0
T-707	1		Hydrazine Storage Tank	1.00	\$12,400	1997	\$12,400	0.93	\$12,400	2.47	\$30,628	\$41,635

A700						Subtotal	\$1,381,507		\$1,110,525	2.47	\$2,742,997	\$3,647,545
-------------	--	--	--	--	--	-----------------	--------------------	--	--------------------	------	--------------------	--------------------

P-1000	1	1	Methanol Feed Pump	2.07	\$7,500	1997	\$15,000	0.79	\$26,697	2.47	\$65,941	\$89,639
H-1401A	1		Pinch HX System		\$61,300	2007	\$61,300	0.6	\$61,300	2.47	\$151,411	\$151,411
H-1401B	1		Pinch HX System		\$21,900	2007	\$21,900	0.6	\$21,900	2.47	\$54,093	\$54,093
H-1401C	1		Pinch HX System		\$32,600	2007	\$32,600	0.6	\$32,600	2.47	\$80,522	\$80,522
H-1410	1		Pinch HX System		\$17,600	2007	\$17,600	0.6	\$17,600	2.47	\$43,472	\$43,472
H-1411B	1		Pinch HX System		\$121,000	2007	\$121,000	0.6	\$121,000	2.47	\$298,870	\$298,870
H-1412	1		post MTG Reactor #1	0.47	\$26,400	2007	\$26,400	0.6	\$16,741	2.47	\$41,351	\$41,351
H-1413	1		post MTG Reactor #3 Air Cooled	0.37	\$26,700	2007	\$26,700	0.6	\$14,715	2.47	\$36,346	\$36,346
H-1414	1		post MTG Reactor #4 water cooled	0.94	\$4,743	2002	\$4,743	0.6	\$4,564	2.47	\$11,272	\$14,971
H-1416	1		Pinch HX System		\$0	2007	\$0	0.6	\$0	2.47	\$0	\$0
R-1410	1		MTG Reactor	0.25	\$3,700,000	1999	\$3,700,000	0.65	\$1,502,667	2.47	\$3,711,587	\$4,992,494
S-1401	1		Mixed HC Condensation Knock-out	0.27	\$55,447	2002	\$55,447	0.6	\$25,514	2.47	\$63,020	\$83,698

A1400						Subtotal	\$4,082,690		\$1,845,298	2.47	\$4,557,886	\$5,886,866
--------------	--	--	--	--	--	-----------------	--------------------	--	--------------------	------	--------------------	--------------------

D-1502	1		Absorber Column	1.04	\$347,300	2007	\$347,300	0.68	\$357,838	2.47	\$883,859	\$883,859
D-1503	1		Deethanizer Column	0.86	\$236,400	2007	\$236,400	0.68	\$214,037	2.47	\$528,672	\$528,672

D-1504	1	Stabilizer Column	0.87	\$236,400	2007	\$236,400	0.68	\$214,421	2.47	\$529,619	\$529,619
D-1505	1	Splitter Column	0.81	\$347,300	2007	\$347,300	0.68	\$301,841	2.47	\$745,548	\$745,548
D-1506	1	LPG/ Alkylate Splitter	1.13	\$347,300	2007	\$347,300	0.68	\$377,954	2.47	\$933,547	\$933,547
H-1503R	1	De-ethanizer Column Reboiler	0.22	\$29,600	1997	\$29,600	0.68	\$10,676	2.47	\$26,369	\$35,846
H-1504C	1	Stabilizer Column Condenser	0.13	\$338,016	2002	\$338,016	0.44	\$139,141	2.47	\$343,677	\$456,441
H-1504R	1	Stabilizer Column Reboiler	0.74	\$29,600	1997	\$29,600	0.68	\$24,071	2.47	\$59,454	\$80,821
H-1505	1	Pinch HX System		\$18,000	2007	\$18,000	0.6	\$18,000	2.47	\$44,460	\$44,460
H-1505B	1	Pinch HX System		\$21,100	2007	\$21,100	0.6	\$21,100	2.47	\$52,117	\$52,117
H-1505C	1	Splitter Column Condenser	0.03	\$338,016	2002	\$338,016	0.44	\$71,403	2.47	\$176,364	\$234,231
H-1505R	1	Splitter Column Reboiler	0.15	\$29,600	1997	\$29,600	0.68	\$8,247	2.47	\$20,370	\$27,690
H-1506A	1	Pinch HX System		\$18,900	2007	\$18,900	0.6	\$18,900	2.47	\$46,683	\$46,683
H-1506B	1	Pinch HX System		\$17,600	2007	\$17,600	0.6	\$17,600	2.47	\$43,472	\$43,472
H-1506C	1	Pinch HX System		\$17,600	2007	\$17,600	0.6	\$17,600	2.47	\$43,472	\$43,472
H-1506D	1	Pinch HX System		\$21,600	2007	\$21,600	0.6	\$21,600	2.47	\$53,352	\$53,352
H-1508	1	Pinch HX System		\$18,100	2007	\$18,100	0.6	\$18,100	2.47	\$44,707	\$44,707
H-1512B	1	Lean Oil Recycle Cooler #2	0.06	\$20,889	2002	\$20,889	0.44	\$6,032	2.47	\$14,899	\$19,788
H-1591	1	LPB product cooler - cw	0.00	\$90,000	2007	\$90,000	0.44	\$0	2.47	\$0	\$0
H-1593	1	Gasoline product cooler - cw	12.29	\$30,500	2007	\$30,500	0.44	\$91,982	2.47	\$227,196	\$227,196
P-1503	1	Crude Hydrocarbons Pump	0.90	\$7,500	1997	\$7,500	0.79	\$6,915	2.47	\$17,079	\$23,217
P-1503B	1	D1503 Reboiler Pump	0.91	\$7,500	1997	\$7,500	0.79	\$6,987	2.47	\$17,259	\$23,461
P-1504B	1	D1504 Reboiler Pump	0.80	\$7,500	1997	\$7,500	0.79	\$6,258	2.47	\$15,457	\$21,011
P-1505B	1	D1505 Reboiler Pump	0.39	\$7,500	1997	\$7,500	0.79	\$3,577	2.47	\$8,836	\$12,011
P-1505C	1	D1505 Reflux Pump	0.32	\$7,500	1997	\$7,500	0.79	\$3,071	2.47	\$7,585	\$10,310
P-1508	1	D1503 Reflux Pump	0.12	\$7,500	1997	\$7,500	0.79	\$1,423	2.47	\$3,515	\$4,778
P-1590	1	LPG Product Pump	0.09	\$7,500	1997	\$7,500	0.79	\$1,114	2.47	\$2,751	\$3,739
P-1592	1	Gasoline Product Pump	0.74	\$7,500	1997	\$7,500	0.79	\$5,940	2.47	\$14,671	\$19,944
R-1506	1	Refrigeration for LPG/Alkylate Splitter	0.02	\$700,879	2007	\$700,879	0.6	\$56,448	1.6	\$90,317	\$90,317

R-1590	1	Refrigeration for liquefying LPG	0.02	\$700,879	2007	\$700,879	0.6	\$57,859	1.6	\$92,575	\$92,575
R-1505	1	HF Alkylation Unit	0.25	\$7,080,000	1999	\$7,080,000	0.65	\$2,875,306	2.47	\$7,102,005	\$9,552,978
T-1590	1	LPG Product Storage Tank	0.09	\$165,800	1997	\$165,800	0.51	\$48,401	2.47	\$119,551	\$162,515
T-1592	1	Gasoline Product Storage Tank	0.74	\$165,800	1997	\$165,800	0.51	\$142,625	2.47	\$352,285	\$478,888
A1500					Subtotal	\$10,096,221		\$5,112,591	2.47	\$12,628,100	\$15,493,644
					Equipment Cost	\$58,441,244		\$44,265,099	2.47	\$109,334,794	\$142,507,681

Appendix E. Economic Summary Page from Excel Spreadsheet

Gasoline via Biomass Gasification/MeOH Synthesis and MTG Process Engineering Analysis

2012 Market Target Case: 2010 Tar Reforming Goal & MTG Production

2,000 Dry Metric Tonnes Biomass per Day

BCL Gasifier, Tar Reformer, Sulfur Removal, WGS & Cu/ZnO/Al₂O₃ & ZSM-5 catalysts, Fuel Purification, Steam-Power Cycle
All Values in 2007\$

Energy Plant Gate Price (\$/MMBtu) **\$16.60**
Gasoline Plant Gate Price (\$/gal) **\$1.95** **\$1.39/gee**
LPG Plant Gate Price* (\$/gal) **\$1.53**
Electricity Plant Gate Price (\$/kW-hr) **\$0.0567**

Gasoline Production at Operating Capacity (MM Gal / year) 42.5
Gasoline Product Yield (gal / Dry US Ton Feedstock) 55.1
LPG Production at Operating Capacity (MM Gal / year) 7.1
LPG Product Yield (gal / Dry US Ton Feedstock) 9.3
Delivered Feedstock Cost \$/Dry US Ton \$51
Internal Rate of Return (After-Tax) 10%
Equity Percent of Total Investment 100%

Capital Costs		Operating Costs (cents/mmBtu product)			cents/gal gasoline		
Feed Handling & Drying	\$25,000,000	Feedstock	692.2	81.3	41.7%		
Gasification	\$14,600,000	Natural Gas	0.0	0.0	0.0%		
Tar Reforming, Quench, & Compression	\$27,400,000	Catalysts	6.8	0.8	0.4%		
Acid Gas & Sulfur Removal	\$12,100,000	Olivine	8.2	1.0	0.5%		
Alcohol Synthesis - Compression	\$10,400,000	Other Raw Materials	26.9	3.2	1.6%		
Alcohol Degassing	\$4,800,000	Waste Disposal	10.6	1.2	0.6%		
MTG Process	\$21,600,000	Electricity Transfer	0.0	0.0	0.0%		
Steam System & Power Generation	\$23,100,000	Electricity	0.0	0.0	0.0%		
Cooling Water & Other Utilities	\$5,900,000	Fixed Costs	243.8	28.6	14.7%		
Total Installed Equipment Cost	\$144,900,000	Co-product credits	0.0	0.0	0.0%		
Indirect Costs	54,600,000	Capital Depreciation	175.0	20.6	10.5%		
(% of TPI)	27.4%	Average Income Tax	126.8	14.9	7.6%		
Project Contingency	4,200,000	Average Return on Investment	369.9	43.4	22.3%		
Total Project Investment (TPI)	\$199,500,000	PGP (Total)	1660.3	195.0	100.0%		
		Operating Costs (\$/yr)					
Installed Equipment Cost per Annual Gallon	\$3.27	Feedstock	\$39,100,000				
Total Project Investment per Annual Gallon	\$4.50	Natural Gas	\$0				
Loan Rate	N/A	Catalysts	\$200,000				
Term (years)	N/A	Olivine	\$500,000				
Capital Charge Factor	0.190	Other Raw Matl. Costs	\$600,000				
		Waste Disposal	\$600,000				
		Electricity Transfer Charge	\$0				
		Electricity	\$0				
		Fixed Costs	\$13,800,000				
		Co-product credits @ \$0.00 per gal	\$0				
		Capital Depreciation	\$9,900,000				
		Average Income Tax	\$7,200,000				
		Average Return on Investment	\$20,900,000				
Gasifier Efficiency - HHV %	75.3	Total Plant Electricity Usage (KW)	34,314				
Gasifier Efficiency - LHV %	74.9	Electricity Produced Onsite (KW)	34,320				
Efficiency to Gasoline - HHV %	37.6	Electricity from OBL (KW)	0				
Efficiency to Gasoline - LHV %	37.7	Electricity Purchased from Grid (KW)	0				
Overall Plant Efficiency - HHV %	42.6	Electricity Sold to Grid (KW)	6				
Overall Plant Efficiency - LHV %	42.6						
Plant Hours per year	8406	Steam Plant + Turboexpander Power Generated (hp)	48,415				
%	96.0%	Used for Main Compressors (hp)	0				
		Used for Electricity Generation (hp)	48,415				
		Plant Electricity Use (KWh/gal product)	9.1				
		Gasification & Reforming Steam Use (lb/gal)	14.4				
		Water use (gal water/gal gasoline)	6.5				
		Specific Operating Conditions					
		Feed rate	2,000 dry tonnes/day				
			2,205 dry tons/day				
		Feedstock Cost	\$50.70 \$/dry ton				
			\$51.17 \$/maf ton				

*Cost referenced to 60°F; composition is 27wt% C3's and 73wt% C4's, 4ppmwH₂O.

Appendix F. Discounted Cash Flow Rate of Return Summary

DCFROR Worksheet											
Year	-2	-1	0	1	2	3	4	5	6	7	
Fixed Capital Investment	\$19,220,429	\$118,664,036	\$63,287,486								
Working Capital			\$9,888,670								
Loan Payment				\$0	\$0	\$0	\$0	\$0	\$0	\$0	\$0
Loan Interest Payment	\$0	\$0	\$0	\$0	\$0	\$0	\$0	\$0	\$0	\$0	\$0
Loan Principal	\$0	\$0	\$0	\$0	\$0	\$0	\$0	\$0	\$0	\$0	\$0
Fuel Sales				\$70,559,608	\$94,079,478	\$94,079,478	\$94,079,478	\$94,079,478	\$94,079,478	\$94,079,478	\$94,079,478
By-Product Credit				\$14,607	\$19,476	\$19,476	\$19,476	\$19,476	\$19,476	\$19,476	\$19,476
Total Annual Sales				\$70,574,215	\$94,098,954	\$94,098,954	\$94,098,954	\$94,098,954	\$94,098,954	\$94,098,954	\$94,098,954
Annual Manufacturing Cost											
Raw Materials				\$34,255,310	\$39,148,925	\$39,148,925	\$39,148,925	\$39,148,925	\$39,148,925	\$39,148,925	\$39,148,925
Tar reforming catalysts				\$722,179							
Steam reforming catalysts				\$0					\$0		
ZnO				\$0					\$0		
Methanol catalysts				\$515,085	\$0	\$0	\$0	\$515,085	\$0	\$0	
MTG - ZSM5 Catalyst				\$2,485,503	\$2,485,503	\$2,485,503	\$2,485,503	\$2,485,503	\$2,485,503	\$2,485,503	\$2,485,503
Baghouse Bags				\$466,183					\$466,183		
Other Variable Costs				\$2,573,587	\$2,923,327	\$2,923,327	\$2,923,327	\$2,923,327	\$2,923,327	\$2,923,327	\$2,923,327
Fixed Operating Costs				\$13,786,450	\$13,786,450	\$13,786,450	\$13,786,450	\$13,786,450	\$13,786,450	\$13,786,450	\$13,786,450
Total Product Cost				\$54,804,297	\$58,344,206	\$58,344,206	\$58,344,206	\$58,859,291	\$58,810,389	\$58,344,206	

DCFRR Worksheet continued

	8	9	10	11	12	13	14	15	16	17	18	19	20
													(\$9,888,670)
	\$0	\$0	\$0	\$0	\$0	\$0	\$0	\$0	\$0	\$0	\$0	\$0	\$0
	\$0	\$0	\$0	\$0	\$0	\$0	\$0	\$0	\$0	\$0	\$0	\$0	\$0
	\$0	\$0	\$0	\$0	\$0	\$0	\$0	\$0	\$0	\$0	\$0	\$0	\$0
	\$94,079,478	\$94,079,478	\$94,079,478	\$94,079,478	\$94,079,478	\$94,079,478	\$94,079,478	\$94,079,478	\$94,079,478	\$94,079,478	\$94,079,478	\$94,079,478	\$94,079,478
	\$19,476	\$19,476	\$19,476	\$19,476	\$19,476	\$19,476	\$19,476	\$19,476	\$19,476	\$19,476	\$19,476	\$19,476	\$19,476
	\$94,098,954	\$94,098,954	\$94,098,954	\$94,098,954	\$94,098,954	\$94,098,954	\$94,098,954	\$94,098,954	\$94,098,954	\$94,098,954	\$94,098,954	\$94,098,954	\$94,098,954
	\$39,148,925	\$39,148,925	\$39,148,925	\$39,148,925	\$39,148,925	\$39,148,925	\$39,148,925	\$39,148,925	\$39,148,925	\$39,148,925	\$39,148,925	\$39,148,925	\$39,148,925
				\$0					\$0				
				\$0					\$0				
	\$0	\$515,085	\$0	\$0	\$0	\$515,085	\$0	\$0	\$0	\$515,085	\$0	\$0	\$0
	\$2,485,503	\$2,485,503	\$2,485,503	\$2,485,503	\$2,485,503	\$2,485,503	\$2,485,503	\$2,485,503	\$2,485,503	\$2,485,503	\$2,485,503	\$2,485,503	\$2,485,503
				\$466,183					\$466,183				
	\$2,923,327	\$2,923,327	\$2,923,327	\$2,923,327	\$2,923,327	\$2,923,327	\$2,923,327	\$2,923,327	\$2,923,327	\$2,923,327	\$2,923,327	\$2,923,327	\$2,923,327
	\$13,786,450	\$13,786,450	\$13,786,450	\$13,786,450	\$13,786,450	\$13,786,450	\$13,786,450	\$13,786,450	\$13,786,450	\$13,786,450	\$13,786,450	\$13,786,450	\$13,786,450
	\$58,344,206	\$58,859,291	\$58,344,206	\$58,810,389	\$58,344,206	\$58,859,291	\$58,344,206	\$58,344,206	\$58,810,389	\$58,859,291	\$58,344,206	\$58,344,206	\$58,344,206

DCFROR Worksheet continued

Year		-2	-1	0	1	2	3	4	5	6
Annual Depreciation										
General Plant										
DDB					\$47,221,405	\$33,729,575	\$24,092,554	\$17,208,967	\$12,292,119	\$8,780,085
SL					\$23,610,702	\$19,675,585	\$16,864,787	\$15,057,846	\$14,340,806	\$14,340,806
Remaining Value					\$118,053,512	\$84,323,937	\$60,231,384	\$43,022,417	\$30,730,298	\$21,950,213
Actual					\$47,221,405	\$33,729,575	\$24,092,554	\$17,208,967	\$14,340,806	\$14,340,806
Steam Plant										
DDB					\$2,437,386	\$2,254,582	\$2,085,488	\$1,929,077	\$1,784,396	\$1,650,566
SL					\$1,624,924	\$1,582,163	\$1,544,806	\$1,513,001	\$1,486,997	\$1,467,170
Remaining Value					\$30,061,091	\$27,806,509	\$25,721,021	\$23,791,944	\$22,007,549	\$20,356,982
Actual					\$2,437,386	\$2,254,582	\$2,085,488	\$1,929,077	\$1,784,396	\$1,650,566
Net Revenue					(\$33,888,872)	(\$229,409)	\$9,576,707	\$16,616,705	\$19,114,462	\$19,297,194
Losses Forward						(\$33,888,872)	(\$34,118,280)	(\$24,541,574)	(\$7,924,869)	\$0
Taxable Income					(\$33,888,872)	(\$34,118,280)	(\$24,541,574)	(\$7,924,869)	\$11,189,593	\$19,297,194
Income Tax					\$0	\$0	\$0	\$0	\$4,363,941	\$7,525,905
Annual Cash Income					\$15,769,919	\$35,754,748	\$35,754,748	\$35,754,748	\$30,875,722	\$27,762,660
Discount Factor		1.21	1.1	1	0.909090909	0.826446281	0.751314801	0.683013455	0.620921323	0.56447393
Annual Present Value	\$225,493,427				\$14,336,290	\$29,549,379	\$26,863,072	\$24,420,974	\$19,171,394	\$15,671,298
Total Capital Investment + Interest		\$23,256,719.02	\$130,530,439.89	\$73,176,155.70						

DCFROR Worksheet continued

7	8	9	10	11	12	13	14	15	16	17	18	19	20
\$6,271,489													
\$14,340,806													
\$15,678,723													
\$14,340,806													
\$1,526,774	\$1,412,266	\$1,306,346	\$1,208,370	\$1,117,742	\$1,033,911	\$956,368	\$884,640	\$818,292	\$756,920	\$700,151	\$647,640	\$599,067	\$554,137
\$1,454,070	\$1,448,478	\$1,448,478	\$1,448,478	\$1,448,478	\$1,448,478	\$1,448,478	\$1,448,478	\$1,448,478	\$1,448,478	\$1,448,478	\$1,448,478	\$1,448,478	\$1,448,478
\$18,830,209	\$17,417,943	\$16,111,597	\$14,903,228	\$13,785,485	\$12,751,574	\$11,795,206	\$10,910,566	\$10,092,273	\$9,335,353	\$8,635,201	\$7,987,561	\$7,388,494	\$6,834,357
\$1,526,774	\$1,448,478	\$1,448,478	\$1,448,478	\$1,448,478	\$1,448,478	\$1,448,478	\$1,448,478	\$1,448,478	\$1,448,478	\$1,448,478	\$1,448,478	\$1,448,478	\$1,448,478
\$19,887,169	\$34,306,271	\$33,791,185	\$34,306,271	\$33,840,088	\$34,306,271	\$33,791,185	\$34,306,271	\$34,306,271	\$33,840,088	\$33,791,185	\$34,306,271	\$34,306,271	\$34,306,271
\$0	\$0	\$0	\$0	\$0	\$0	\$0	\$0	\$0	\$0	\$0	\$0	\$0	\$0
\$19,887,169	\$34,306,271	\$33,791,185	\$34,306,271	\$33,840,088	\$34,306,271	\$33,791,185	\$34,306,271	\$34,306,271	\$33,840,088	\$33,791,185	\$34,306,271	\$34,306,271	\$34,306,271
\$7,755,996	\$13,379,446	\$13,178,562	\$13,379,446	\$13,197,634	\$13,379,446	\$13,178,562	\$13,379,446	\$13,379,446	\$13,197,634	\$13,178,562	\$13,379,446	\$13,379,446	\$13,379,446
\$27,998,752	\$22,375,303	\$22,061,101	\$22,375,303	\$22,090,931	\$22,375,303	\$22,061,101	\$22,375,303	\$22,375,303	\$22,090,931	\$22,061,101	\$22,375,303	\$22,375,303	\$22,375,303
0.513158118	0.46650738	0.424097618	0.38554329	0.3504939	0.318630818	0.28966438	0.26333125	0.23939205	0.217629136	0.19784467	0.17985879	0.163507991	0.148643628
\$14,367,787	\$10,438,244	\$9,356,060	\$8,626,648	\$7,742,737	\$7,129,461	\$6,390,315	\$5,892,117	\$5,356,470	\$4,807,630	\$4,364,671	\$4,024,395	\$3,658,541	\$3,325,946
													(\$1,469,887.74)

Appendix G. Heat Exchanger Network

*Note: It is expected that anyone building this type of BTG plant would create their own heat exchanger network, and thus due to time restrictions, the heat exchanger network has not been updated to reflect recent model modifications.

	Name	Duty	Areas (ft ²)	Shls/Ft	Spec	Stream Name	Tin (°F)	Tout (°F)
1	H-200A (N1)	3.85E+6	74.47	1	Duty	286	1627.19	1600.20
			74.45	1.000		200	382.75	494.46
2	H-200B (N2)	191000.0	6.57	1	Duty	311	1158.48	1157.00
			6.57	1.000		200	494.46	500.00
3	H-209A (N3)	9.84E+6	1446.53	1	Duty	504	417.34	361.92
			1398.51	0.967		209	184.55	273.89
4	H-209B (N4)	2.17E+6	1647.78	1	Duty	412	320.80	309.35
			1581.82	0.960		209	273.89	293.58
5	H-209C (N5)	1.17E+7	2926.27	1	Duty	412	482.00	420.12
			2588.45	0.885		209	293.58	400.00
6	H-315D (N6)	1.37E+7	615.22	1	Duty	286	1816.31	1719.89
			569.53	0.926		315D	533.40	1624.00
7	H-416B (N7)	1.32E+7	332.69	1	Duty	286	1719.89	1627.19
			325.80	0.979		416	140.77	1199.76
8	H-410F (N8)	3.20E+7	675.29	1	Duty	286	1600.20	1375.78
			671.94	0.995		410	328.46	483.45
9	H-605F (N9)	3.70E+7	1032.60	1	Duty	286	1375.78	1116.21
			1027.00	0.995		605	382.75	466.36
10	H-642 (N10)	2.31E+6	81.59	1	Duty	286	1116.21	1100.00
			81.59	1.000		642	464.99	465.00
11	H-301A (N11)	1.14E+8	6067.67	2	Duty	301	1621.87	560.71
			6066.54	1.000		642	464.27	464.98
12	H-605E (N12)	1.99E+7	5538.15	2	Duty	301	560.71	370.80
			5251.13	0.948		605	337.75	382.75
13	H-1505A (N13)	642000.0	69.79	1	Duty	301	370.80	364.69
			69.64	0.998		R1505	111.30	200.00
14	H-410A (N14)	5.48E+6	700.95	1	Duty	301	364.69	312.44
			690.27	0.985		410	130.00	186.48
15	H-301C (N15)	4.30E+6	669.40	1	Duty	301	312.44	271.47
			667.25	0.997		620	140.00	150.08
16	H-505A (N16)	2.57E+6	496.49	1	Duty	301	271.47	247.00
			493.32	0.994		505	129.97	151.84
17	H-416A (N17)	3.82E+6	685.66	1	Duty	301	247.00	241.07
			683.55	0.997		416	90.91	140.77
18	Cooling Tower (N18)	4.31E+6			Duty	301	241.07	200.00
19	H-607 (N19)	1.08E+8	1438.08	1	Duty	311	2860.00	2003.65
			1407.88	0.979		607	462.23	900.00
20	H-1416 (N20)	235000.0	3.49	1	Duty	311	2003.65	2002.35
			3.49	1.000		1416	90.00	798.85
21	H-505D (N21)	5.00E+7	875.38	1	Duty	311	2002.35	1609.24
			861.14	0.984		505	273.89	700.00
22	H-1401C (N22)	5.26E+7	1295.25	1	Duty	311	1609.24	1196.22
			1248.30	0.964		1401	210.78	680.00

23	H-315A (N23)	1.39E+6	39.94	1	Duty	311	1196.22	1185.32
			39.89	0.999		315A	202.00	570.00
24	H-410G (N24)	3.42E+6	114.22	1	Duty	311	1185.32	1158.48
			114.21	1.000		410	483.45	500.00
25	H-315DB(N52)	2.80E+6	100.75	1	Duty	311	1157.00	1152.00
			100.74	1.000		315D	513.00	533.40
26	H-330A (N25)	169000.0	53.10	1	Duty	592	205.34	203.30
			53.09	1.000		330	130.92	133.11
27	H-330B (N26)	580000.0	203.73	1	Duty	504	203.27	200.00
			203.53	0.999		330	133.11	140.66
28	H-330C (N27)	8.96E+6	2007.24	1	Duty	504	338.49	288.02
			1832.78	0.913		330	140.66	257.25
29	H-330D (N28)	1.10E+7	2491.88	1	Duty	504	479.13	417.34
			2174.54	0.873		330	257.25	400.00
30	H-630B (N29)	252000.0	121.61	1	Duty	630	234.37	234.00
			121.60	1.000		410	186.48	187.75
31	H-410C (N30)	3.20E+6	2022.92	2	Duty	412	278.36	224.52
			1864.98	0.922		410	187.75	237.10
32	H-410D (N31)	4.16E+6	924.03	1	Duty	504	361.92	338.49
			917.15	0.993		410	237.10	257.25
33	H-410E (N32)	1.47E+7	5292.15	2	Duty	412	398.41	320.80
			5005.81	0.946		410	257.25	328.46
34	H-411 (N33)	2.06E+7	12855.29	3	Duty	411	224.52	200.00
			12647.44	0.984		620	150.08	198.00
35	H-605D (N34)	4.11E+6	1235.68	1	Duty	412	420.12	398.41
			1228.44	0.994		605	328.46	337.75
36	H-505C (N35)	5.07E+6	3058.17	1	Duty	412	309.35	278.36
			2600.20	0.850		505	223.89	273.89
37	H-505B (N36)	8.46E+6	2852.38	1	Duty	504	288.02	240.38
			2539.01	0.890		505	151.84	223.89
38	H-1506D (N37)	1.48E+6	517.25	1	Duty	504	240.38	232.05
			505.28	0.977		1506	129.97	200.00
39	H-1401A (N38)	5.11E+6	3165.76	1	Duty	504	232.05	203.27
			2733.82	0.864		1401	151.84	197.46
40	H-1508 (N39)	165000.0	48.93	1	Duty	592	251.85	249.85
			48.76	0.997		1508	141.01	200.00
41	Cooling Tower (N40)	3.67E+6			Duty	592	249.85	205.34
42	H-1506B (N41)	272000.0	66.31	1	Duty	592	203.30	200.00
			66.25	0.999		1506	101.89	114.75
43	H-605A (N42)	707000.0	165.73	1	Duty	R1500	370.80	300.00
			165.39	0.998		605	233.43	235.03
44	H-605B (N43)	3.71E+7	22318.80	5	Duty	1411	354.57	277.31
			21666.52	0.971		605	235.03	318.88
45	H-605C (N44)	4.24E+6	1425.73	1	Duty	1412	449.70	354.57
			1376.62	0.966		605	318.88	328.46
46	H-630A (N45)	2.59E+6	1374.95	1	Duty	630	255.59	234.37
			1357.87	0.988		620	198.00	204.48
47	H-1505B (N46)	783000.0	456.80	1	Duty	1505	252.88	236.89
			455.32	0.997		620	204.48	206.32
48	H-1411B (N47)	1.31E+7	7244.42	2	Duty	1411	277.31	250.00
			7097.65	0.980		620	206.32	237.10
49	H-1410 (N48)	1.32E+6	99.85	1	Duty	1410	778.91	752.00
			99.85	1.000		642	464.98	464.99
50	H-1401B (N49)	1.49E+6	541.17	1	Duty	1505	283.36	252.88
			531.99	0.983		1401	197.46	210.78

51	H-1506A (N50)	227000.0	32.33	1	Duty	1512	319.68	205.84
			32.07	0.992		1506	91.15	101.89
52	H-1506C (N51)	322000.0	70.63	1	Duty	1592	257.46	200.00
			69.68	0.987		1506	114.75	129.97

Appendix H. Process Flow Diagrams

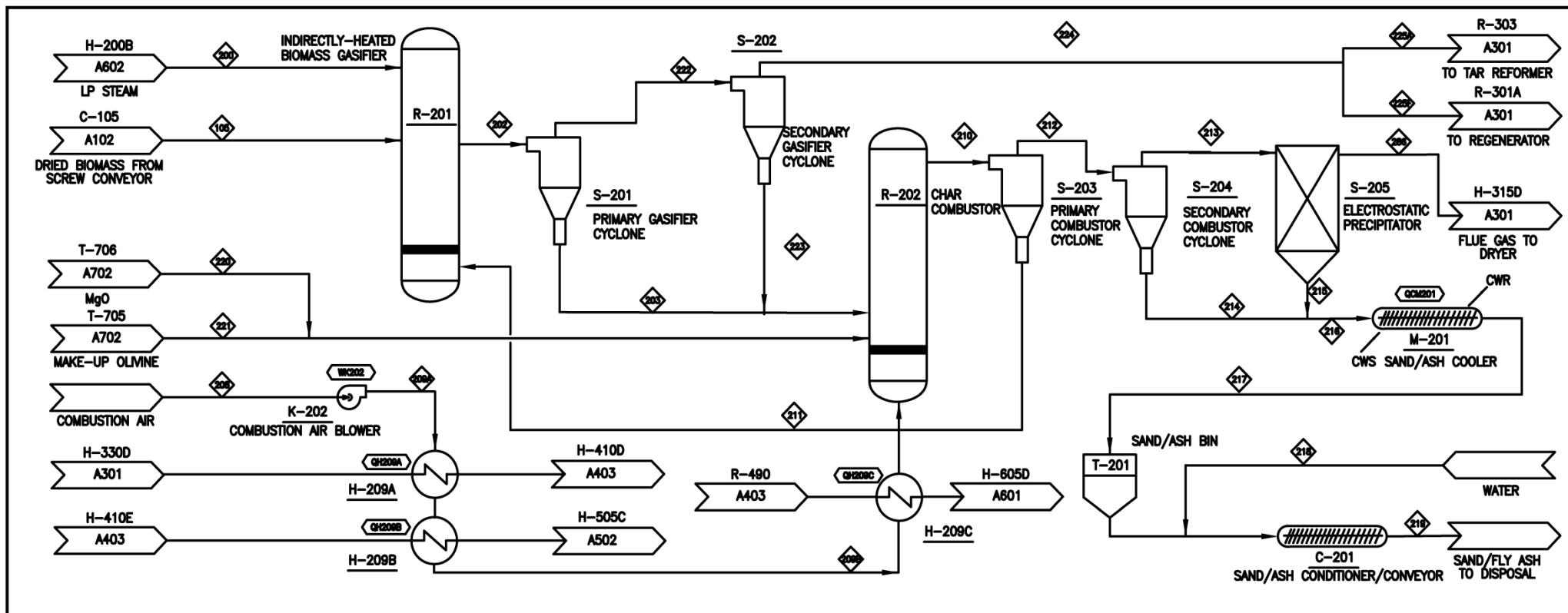

COMPONENT	UNITS	105	200	202	203	208	209B	210	211	212	213	214	215	216	217	218	219	220	221	222	223	224	286		
Total Flow	lb/hr	204,131	73,120	5,277,340	5,030,688	444,855	444,855	5,481,400	5,000,089	481,311	479,123	2,188	2	2,190	2,190	243	2,433	7	543	246,653	5,307	241,346	479,121		
Temperature	F	220	383	1,622	30	185	1,816	1,816		1,816	1,816						206	60	60	1,622	1,622	1,816			
Pressure	Psia	25.0	25.0	23.0	21.8	14.7	22.0	21.4	25.0	22.0	22.0	21.7	21.7	21.7	14.7	14.7	14.7	25.0	22.0	21.8	21.4	21.4	22.0		
Vapor Fraction		0.00	1.00	1.00	0.00	1.00	1.00	1.00	0.00	1.00	1.00	0.00	0.00	0.00	0.00	0.00	0.00	1.00	1.00	1.00	0.00	1.00	1.00		
Hydrogen	lb/hr			3,337																3,337		3,337			
Water	lb/hr	20,413	73,120	93,533		8,680	8,680	27,595		27,595	27,595					243	243			93,533	93,533	27,595			
Carbon Monoxide	lb/hr			78,841																78,841		78,841			
Nitrogen	lb/hr					329,407	329,407	329,428		329,428	329,428													329,428	
Oxygen	lb/hr					100,931	100,931	16,826		16,826	16,826													16,826	
Argon	lb/hr					5,618	5,618	5,618		5,618	5,618													5,618	
Carbon Dioxide	lb/hr					37,079	219	219	99,626	99,626	99,626										37,079	37,079	99,626		
Hydrogen Sulfide (H ₂ S)	lb/hr			161																0	0	161		161	
SO ₂	lb/hr							27		27	27													27	
Ammonia (NH ₃)	lb/hr			355																355		355		355	
NO ₂	lb/hr																							0	
Methane	lb/hr			16,338				0		0	0									16,338		16,338		16,338	
isobutane	lb/hr																								
n-butane	lb/hr																								
ethane (C ₂ H ₆)	lb/hr			504																504		504		504	
ethylene (C ₂ H ₄)	lb/hr			7,943																7,943		7,943		7,943	
acetylene (C ₂ H ₂)	lb/hr			730																730		730		730	
Benzene (C ₆ H ₆)	lb/hr			618																618		618		618	
Tar (C ₁₀ H ₈)	lb/hr			1,854																1,854		1,854		1,854	
Methanol	lb/hr																								
DME	lb/hr																								
Carbon (Solid)	lb/hr																								
Sulfur (Solid)	lb/hr																								
Olivine (Solid)	lb/hr			5,000,000	4,995,000			5,000,500	5,000,000	500	1	500	1	500	500					500	7	543	5,000	4,950	50
Wood	lb/hr																								
Ash	lb/hr	0		0	0			1,779	89	1,690	2	1,688	2	1,690	1,690					0	0	0		0	
Char	lb/hr	0		36,048	35,688			0	0	0	0			0	0					360	357	4			
Enthalpy Flow	MMBTU/hr	-553	-412	1,281	1,946	-50	-39	1,933	2,242	-309	-310	0	0	0	0	-2	-2	0	0	-666	2	-668	-310		
Average Density	lb/ft ³																								

Heat Stream No.	MM BTU/hr	Work Stream No.	HP
QCIM201	0.87	WK202	4048.2
QH209A	9.84		
QH209B	2.17		
QH209C	11.70		

Eq. No.	Equipment Name	Req.	Spare	Equipment Type
C-201	Sand/ash Conditioner/Conveyor	1		SCREW
H-209A	Pinch HX System	1		DHE U TUBE
H-209B	Pinch HX System	1		DHE U TUBE
H-209C	Pinch HX System	1		DHE U TUBE
K-202	Combustion Air Blower	2		CENTRIFUGAL
M-201	Sand/ash Cooler	2		MISCELLANEOUS
R-201	Indirectly-heated Biomass Gasifier	2		VERTICAL-VESSEL
R-202	Char Combustor	2		VERTICAL-VESSEL
S-201	Primary Gasifier Cyclone	2		GAS CYCLONE
S-202	Secondary Gasifier Cyclone	2		GAS CYCLONE
S-203	Primary Combustor Cyclone	2		GAS CYCLONE
S-204	Secondary Combustor Cyclone	2		GAS CYCLONE
S-205	Electrostatic Precipitator	2		MISCELLANEOUS
T-201	Sand/ash Bin	1		FLAT-BTM-STORAGE

USE COMMENTS:
 1 Thermodynamic Data Report: 2-10-04
 2 2-10-04
 3 6-25-04
 4 6-17-04
 5 11-17-04
 6 To Edward Data Report: 11-17-04
 7 HYSYS Data Report: 07-07-04
 8 07-07-04

NATIONAL RENEWABLE ENERGY LABORATORY
 National Bioenergy Center
SECTION A200 GASIFICATION
 6 fluidized bed no PFD-P850-A201 F

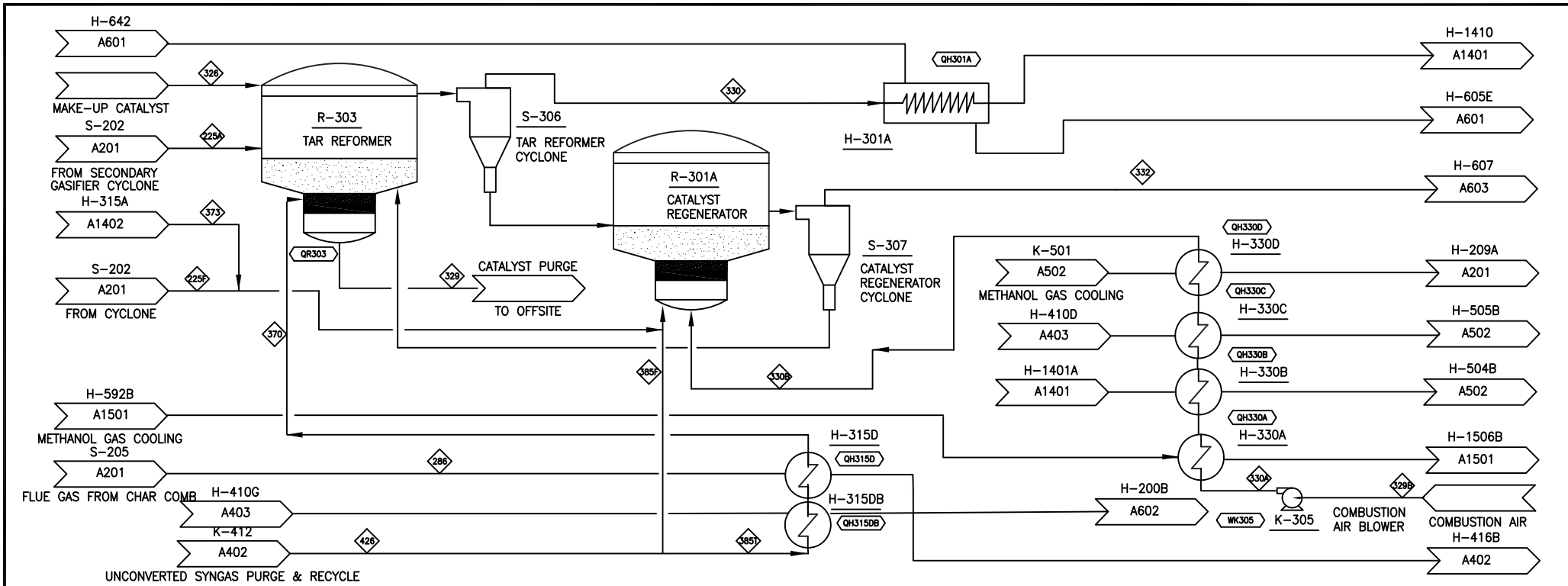

COMPONENT	UNITS	225A	225F	286	300	326	329	330	330B	330A	370	373	385F	385T	426
Total Flow	lb/hr	184,278	57,068	479,121	207,125	1	1	207,125	207,127	316,844	22,849	7,666	2,539	22,849	25,387
Temperature	F	1,622	1,622	1,616	140			1,622	1,622	131	1,624	570	513	513	513
Pressure	Psia	21.4	21.4	22.0	14.5	22.0	16.5	16.5	16.5	17.6	33.2	59.0	33.7	33.7	33.7
Vapor Fraction		1.00	1.00	1.00	1.00	0.00	0.00	1.00	1.00	1.00	1.00	1.00	1.00	1.00	1.00
Hydrogen	lb/hr	2,546	789					12,093	12,093		1,879	13	209	1,879	2,088
Water	lb/hr	71,417	22,117	27,595	40,892			40,892	40,892	6,182	5	4	1	5	6
Carbon Monoxide	lb/hr	60,198	16,642					101,715	101,715	11,253	100	1,250	11,253	12,503	
Nitrogen	lb/hr			329,428	1,913			1,913	1,913	234,617	1,707	14	190	1,707	1,897
Oxygen	lb/hr			16,826						71,887					
Argon	lb/hr			5,618						4,002					
Carbon Dioxide	lb/hr	28,311	8,768					46,805	46,805	156	4,426	1,626	492	4,426	4,918
Hydrogen Sulfide (H ₂ S)	lb/hr	123	38					123	123	0	0	0	0	0	0
SO ₂	lb/hr			27						0	0	0	0	0	0
Ammonia (NH ₃)	lb/hr	271	84					28	28	7	19	1	7	8	
NO ₂	lb/hr			0											
Methane	lb/hr	12,475	3,863					3,019	3,019	2,621	454	291	2,621	2,912	
isobutane	lb/hr									570					
n-butane	lb/hr									245					
ethane (C ₂ H ₆)	lb/hr	385	119					4	4	3	211	0	3	3	
ethylene (C ₂ H ₄)	lb/hr	6,065	1,878					658	658	511	280	57	511	568	
acetylene (C ₂ H ₂)	lb/hr	557	173					60	60	41	14	5	41	46	
Benzene (C ₆ H ₆)	lb/hr	472	146					5	5	0	0	0	0	0	
Tar (C ₁₀ H ₈)	lb/hr	1,415	438					1	1	0	0	0	0	0	
Methanol	lb/hr			0				0	0	394	2,595	44	394	437	
DME	lb/hr														
Carbon (Solid)	lb/hr														
Sulfur (Solid)	lb/hr														
Olivine (Solid)	lb/hr	38	12					38	38						
Wood	lb/hr														
Ash	lb/hr	0	0					0	0						
Char	lb/hr	3	1					3	3						
Enthalpy Flow	MMBTU	-510	-158	-310	-588	0	0	-429	-429	-32	-20	-15	-4	-36	-40
Average Density	lb/ft ³														

Heat Stream No.	MM BTU/hr	Work Stream No.	HP
QH301A	111.00	WK305	1246.4
QH330A	0.17		
QH330B	0.58		
QH330C	8.96		
QH330D	11.00		
QH315D	13.70		

Eq. No.	Equipment Name	Req.	Spare	Equipment Type
H-301A	Pinch HX System	1		DHE FIXED T S
H-315D	Pinch HX System	1		DHE JACKETED
H-330A	Pinch HX System	1		DHE FIXED T S
H-330B	Pinch HX System	1		DHE FIXED T S
H-330C	Pinch HX System	1		DHE FIXED T S
H-330D	Pinch HX System	1		DHE FIXED T S
K-305	Regenerator Combustion Air Blower	1		CENTRIFUGAL
R-301A	Tar Reformer Catalyst Regenerator	1		VERTICAL-VESSEL
R-303	Tar Reformer	1		VERTICAL-VESSEL
S-306	Tar Reformer Cyclone	1		GAS CYCLONE
S-307	Catalyst Regenerator Cyclone	1		GAS CYCLONE

REV	DESCRIPTION	DATE
A	Thermochemical Design Report	8-19-04
B		8-25-04
C		8-17-04
D		11-17-04
E	TC Ethanol Design Report	12-17-06
F	BTG Design Report	07-23-09

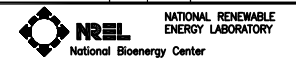

NATIONAL BIOENERGY CENTER
SECTION A300
TAR REFORMING, CLEANUP, & COMPRESSION

6 fluidized bed no PFD-P850-A301 F

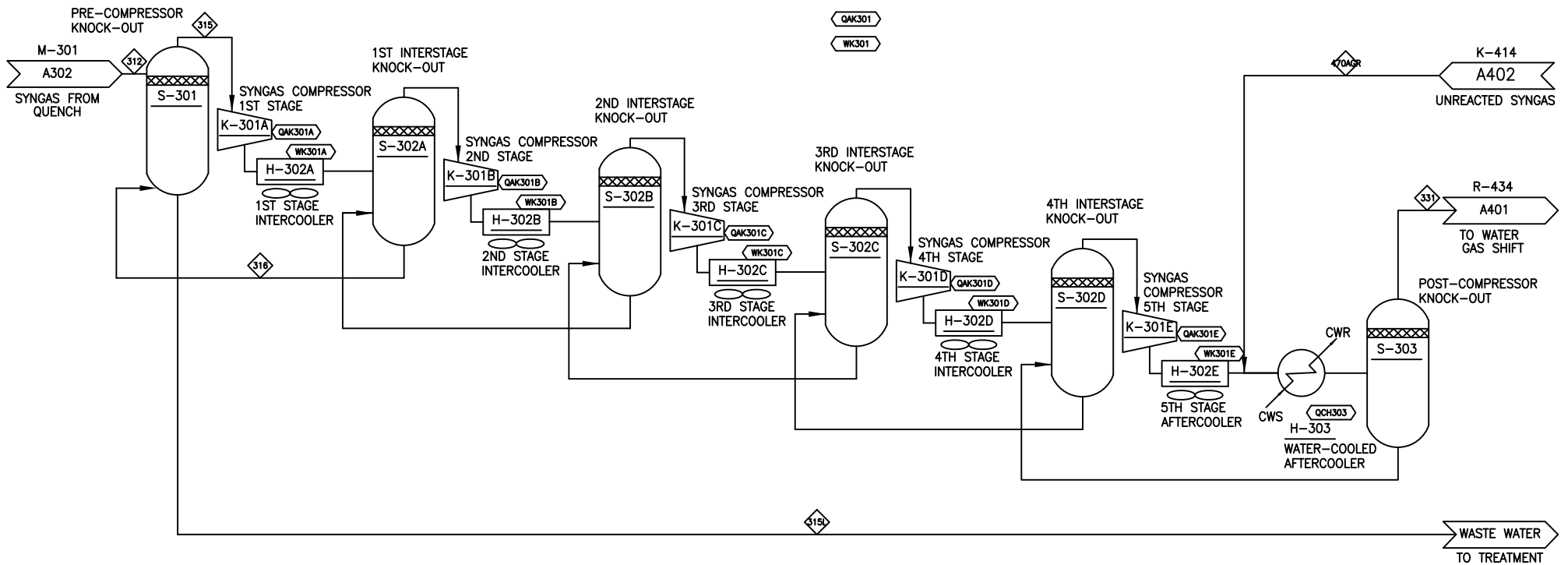

COMPONENT	UNITS	312	314	315	316	331
Total Flow	lb/hr	201,166	44,470	201,175	33,933	167,242
Temperature	F	130	72	137	137	140
Pressure	Psia	15.0	35.0	15.0	15.0	745.0
Vapor Fraction		1.00	0.00	1.00	0.00	1.00
Hydrogen	lb/hr	12,093	0	12,093	0	12,093
Water	lb/hr	34,724	44,457	34,727	33,928	799
Carbon Monoxide	lb/hr	101,710	5	101,710	0	101,710
Nitrogen	lb/hr	1,913	0	1,914	0	1,914
Oxygen	lb/hr					
Argon	lb/hr					
Carbon Dioxide	lb/hr	46,809	1	46,812	3	46,809
Hydrogen Sulfide (H ₂ S)	lb/hr	122	0	122	0	122
SO ₂	lb/hr					
Ammonia (NH ₃)	lb/hr	28	0	28	0	28
NO ₂	lb/hr					
Methane	lb/hr	3,018	2	3,018	0	3,018
Isobutane	lb/hr					
n-butane	lb/hr					
ethane (C ₂ H ₆)	lb/hr	4	0	4	0	4
ethylene (C ₂ H ₄)	lb/hr	657	1	657	0	657
acetylene (C ₂ H ₂)	lb/hr	60	0	60	0	60
benzene (C ₆ H ₆)	lb/hr	4	0	4	0	4
tar (C ₁₀ H ₈)	lb/hr	0	1	0	0	0
Methanol	lb/hr	25	2	26	1	25
DME	lb/hr					
Carbon (Solid)	lb/hr					
Sulfur (Solid)	lb/hr					
Oilvine (Solid)	lb/hr					
Wood	lb/hr					
Ash	lb/hr					
Char	lb/hr					
Enthalpy Flow	MMBTU/hr	-554	-304	-553	-232	-358
Average Density	lb/ft ³					

Heat Stream No.	MM BTU/hr	Work Stream No.	IHP
QAK301	112.50	WK301	29729.9
QAK301A	37.31	WK301A	6281.9
QAK301B	24.73	WK301B	6281.5
QAK301C	18.59	WK301C	5791.5
QAK301D	16.63	WK301D	5756.7
QAK301E	15.25	WK301E	5618.3
QCH303	20.72		

Eq. No.	Equipment Name	Req.	Spare	Equipment Type
H-302	Syngas Compressor Intercoolers	5		AIR-COOLED EX-CHA
H-303	Water-cooled Aftercooler	1		SHELL-TUBE
K-301	Syngas Compressor	1		CENTRIFUGAL
S-301	Pre-compressor Knock-out	1		KNOCK-OUT DRUM
S-302	Syngas Compressor Interstage Knock-out	4		KNOCK-OUT DRUM
S-303	Post-compressor Knock-out	1		KNOCK-OUT DRUM

REV	DESCRIPTION	DATE
A	Thermochemical Design Report	3-20-04
B		9-25-04
C		9-17-04
D		11-17-04
E	TC Ethanol Design Report	12-17-08
F	BTG Design Report	07-07-09

NATIONAL RENEWABLE ENERGY LABORATORY
 National Bioenergy Center
SECTION A300
TAR REFORMING, CLEANUP, & COMPRESSION

16 fluidized bed no PFD-P850-A303 F

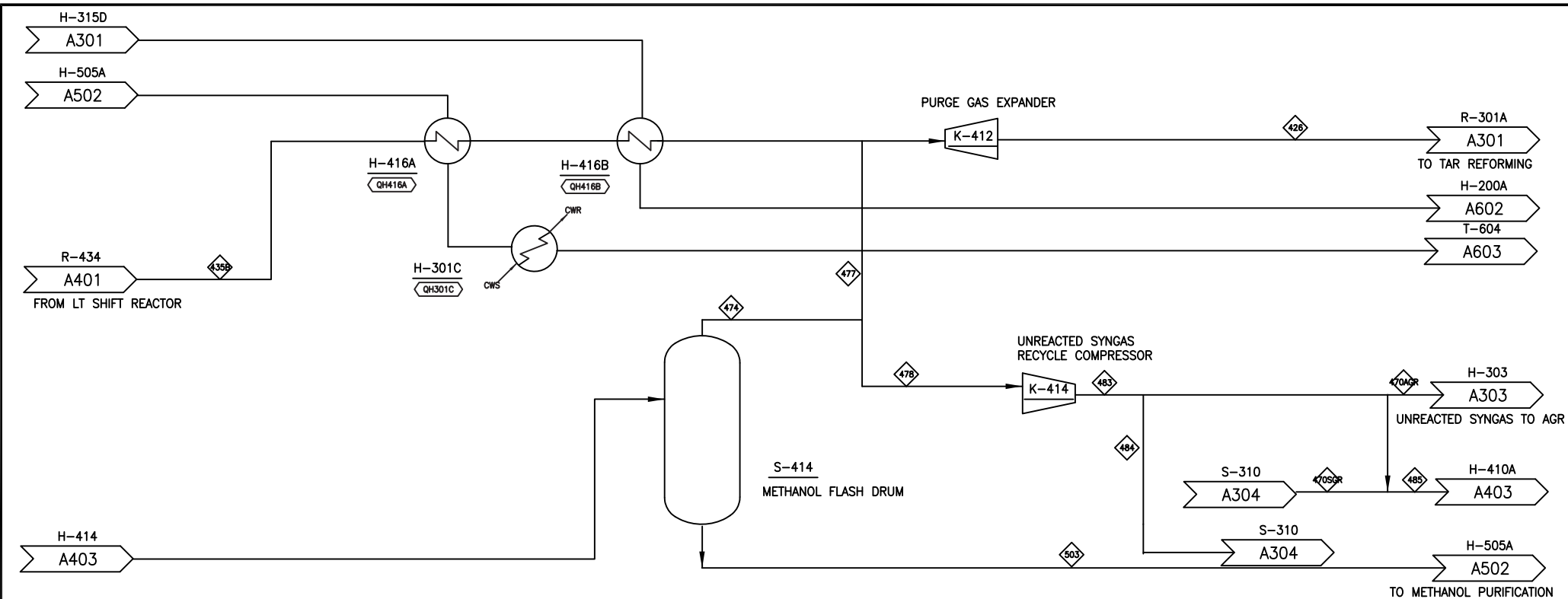

COMPONENT	UNITS	426	435B	466B	470B	470AGR	478	503
Total Flow	lb/hr	25,387	46	179,981		205,413	169,546	88,928
Temperature	F	513	666	280		263	90	131
Pressure	Psia	33.7	745.0	745.0		745.0	569.0	569.0
Vapor Fraction		1.00	1.00	1.00	0.00	1.00	1.00	0.00
Hydrogen	lb/hr	2,088	3	13,043		15,136	13,949	9
Water	lb/hr	6	4	5,058		5,060	10	449
Carbon Monoxide	lb/hr	12,503	7	88,454		100,995	83,609	100
Nitrogen	lb/hr	1,897	0	1,914		3,817	12,688	14
Oxygen	lb/hr							
Argon	lb/hr							
Carbon Dioxide	lb/hr	4,918	30	67,596		72,501	32,704	1,626
Hydrogen Sulfide (H2S)	lb/hr	0	0	122		122	0	0
SO2	lb/hr							
Ammonia (NH3)	lb/hr	8	0	28		35	53	19
NO2	lb/hr							
Methane	lb/hr	2,912	1	3,017		5,939	19,481	105
isobutane	lb/hr							
n-butane	lb/hr							
ethane (C2H6)	lb/hr	3	0	4		7	21	1
ethylene (C2H4)	lb/hr	568	0	657		1,227	3,801	89
acetylene (C2H2)	lb/hr	46	0	60		106	305	14
Benzene (C6H6)	lb/hr	0	0	4		4	4	4
Tar (C10H8)	lb/hr	0	0	0		0	0	0
Methanol	lb/hr	437	0	25		464	2,925	86,498
DME	lb/hr							
Carbon (Solid)	lb/hr							
Sulfur (Solid)	lb/hr							
Colivina (Solid)	lb/hr							
Wood	lb/hr							
Ash	lb/hr							
Char	lb/hr							
Enthalpy Flow	MMBTU/hr	-40	0	-428		-473	-310	-287
Average Density	lb/ft ³							

Heat Stream No.	MM BTU/hr	Work Stream No.	HP
QH416A	0.6224	WK412	-4285.9
QH416B	13.20	WK414	2254.9
QH301C	4.31		

Eq. No.	Equipment Name	Req.	Spare	Equipment Type
H-416A	Pinch HX System	1		DHE U TUBE
H-416B	Pinch HX System	1		DHE U TUBE
K-412	Purge Gas Expander	1		CENTRIFUGAL
K-414	Unreacted Syngas Recycle Compressor	1		CENTRIFUGAL
S-414	Methanol Flash Drum	1		HORIZONTAL-VESSE

REV	DESCRIPTION	DATE
A	Thermochemical Design Report	8-24-04
B		8-25-04
C		9-17-04
D		11-17-04
E	TC Ethanol Design Report	12-17-06
F	BTG Design Report	07-23-09



NATIONAL RENEWABLE ENERGY LABORATORY
National Bioenergy Center

SECTION A400
METHANOL SYNTHESIS

16 fluidized bed no. PFD-P850-A402 F

8807-23-06

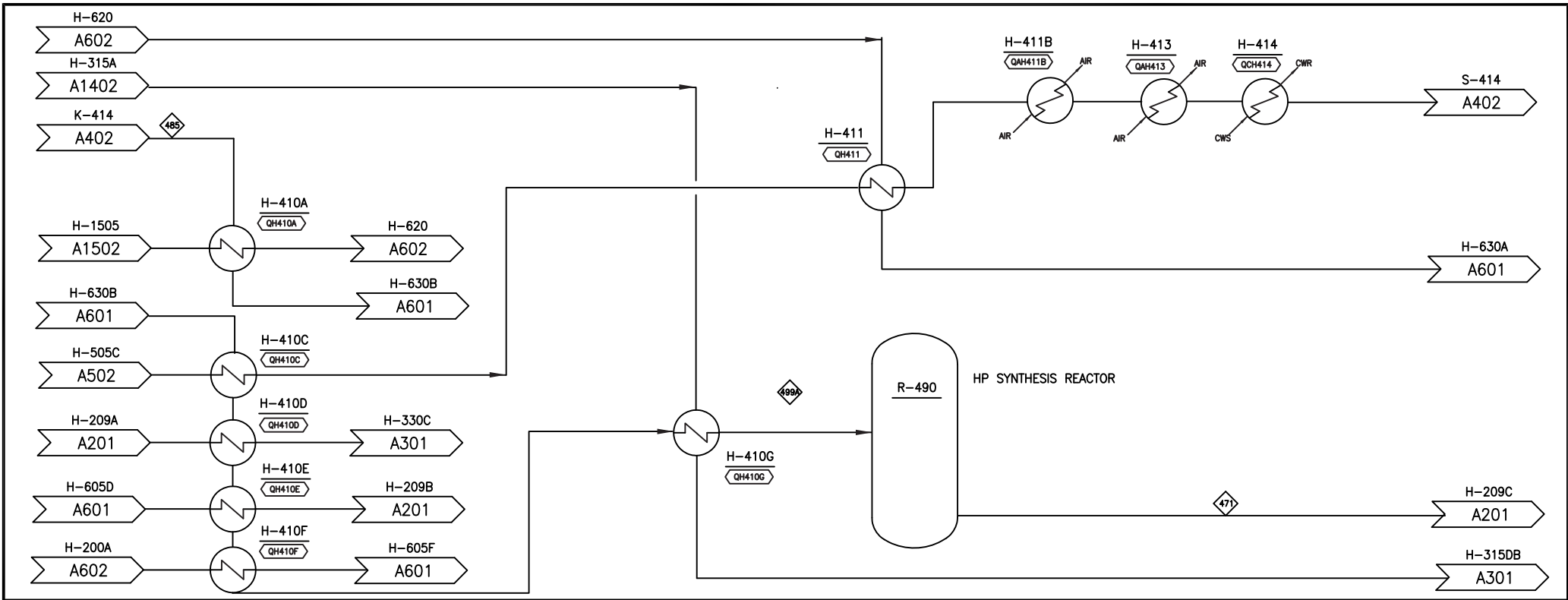

COMPONENT	UNITS	335	470B	470TOSGR	471
Total Flow	lb/hr	384,117	283,816	283,816	283,816
Temperature	F	1,144	30	482	
Pressure	Psia	16.5	735.0	583.0	
Vapor Fraction		1.00	0.00	1.00	
Hydrogen	lb/hr		26,992	16,043	
Water	lb/hr	58,366	372	480	
Carbon Monoxide	lb/hr		172,063	95,202	
Nitrogen	lb/hr	234,821	14,801	14,801	
Oxygen	lb/hr	10,201			
Argon	lb/hr	4,002			
Carbon Dioxide	lb/hr		39,435	39,218	
Hydrogen Sulfide (H2S)	lb/hr		0	0	
SO2	lb/hr	72			
Ammonia (NH3)	lb/hr		80	80	
NO2	lb/hr	281			
Methane	lb/hr		22,498	22,498	
Isobutane	lb/hr				
n-butane	lb/hr				
ethane (C2H6)	lb/hr		25	25	
ethylene (C2H4)	lb/hr		4,457	4,457	
acetylene (C2H2)	lb/hr		365	365	
Benzene (C6H6)	lb/hr		5	5	
Tar (C10H8)	lb/hr		0	0	
Methanol	lb/hr		2,922	89,860	
DME	lb/hr				
Carbon (Solid)	lb/hr				
Sulfur (Solid)	lb/hr				
Olivine (Solid)	lb/hr	12			
Wood	lb/hr				
Ash	lb/hr	0			
Char	lb/hr	1			
Enthalpy Flow	MMBTU/hr	-512	-486	-543	
Average Density	lb/ft ³				

Heat Stream No.	MM BTU/hr	Work Stream No.	HP
QH410A	5.48		
QH410C	10.20		
QH410D	4.16		
QH410E	14.70		
QH410F	32.00		
QH410G	3.24		
QH411	20.60		
QAH411B	25.83		
QAH413	0.36		
QCH414	10.48		

Eq. No.	Equipment Name	Req.	Spare	Equipment Type
H-410A	Pinch HX System	1		DHE U-TUBE
H-410C	Pinch HX System	1		DHE U-TUBE
H-410D	Pinch HX System	1		DHE U-TUBE
H-410E	Pinch HX System	1		DHE U-TUBE
H-410F	Pinch HX System	1		DHE U-TUBE
H-410G	Pinch HX System	1		DHE U-TUBE
H-411	Pinch HX System	1		DHE U-TUBE
H-411B	post Reactor Syngas cooling #3 - Air Cool	1		AIR-COOLED EXCHG
H-413	post Reactor Syngas cooling #3 - Air Cool	1		SHELL-TUBE
H-414	Methanol Condenser	1		SHELL-TUBE
R-490	High pressure Synthesis Reactor	1		VERTICAL-VESSEL

VER	DESCRIPTION	DATE
A	Thermochemical Design Report	8-24-04
B		8-25-04
C		9-17-04
D		11-17-04
E	TC Ethanol Design Report	12-17-06
F	BTG Design Report	07-14-09

SECTION A400
METHANOL SYNTHESIS

16 fluidized bed no. PFD-P850-A403	F
------------------------------------	---

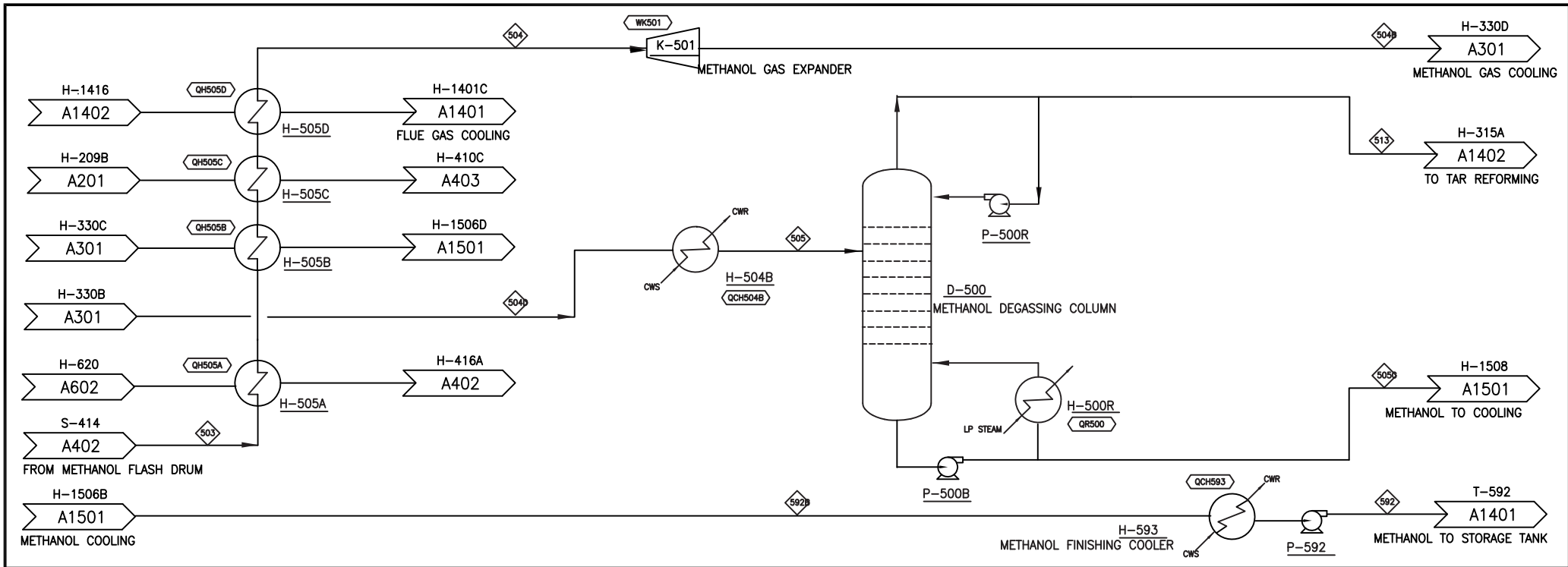

COMPONENT	UNITS	503	504	504B	504D	505C	513	592	592B
Total Flow	lb/hr	88,928	88,928	88,928	88,928	84,353	4,575	84,353	84,353
Temperature	F	131	700	480	200	252	219	149	200
Pressure	Psia	569	567	100	100	98	98	15	98
Vapor Fraction		1	1	0	0	1	0		
Hydrogen	lb/hr	9	9	9	9	9	9	9	9
Water	lb/hr	449	449	449	449	445	3	445	445
Carbon Monoxide	lb/hr	100	100	100	100	100	100	100	100
Nitrogen	lb/hr	14	14	14	14	14	14	14	14
Oxygen	lb/hr								
Argon	lb/hr								
Carbon Dioxide	lb/hr	1,626	1,626	1,626	1,626	0	1,626	0	0
Hydrogen Sulfide (H2S)	lb/hr	0	0	0	0	0	0	0	0
SO2	lb/hr								
Ammonia (NH3)	lb/hr	19	19	19	19	0	19	0	0
NO2	lb/hr								
Methane	lb/hr	105	105	105	105	0	105	0	0
isobutane	lb/hr								
n-butane	lb/hr								
ethane (C2H6)	lb/hr	1	1	1	1	0	1	0	0
ethylene (C2H4)	lb/hr	89	89	89	89	0	89	0	0
acetylene (C2H2)	lb/hr	14	14	14	14	0	14	0	0
Benzene (C6H6)	lb/hr	4	4	4	4	0	4	0	4
Tar (C10H8)	lb/hr	0	0	0	0	0	0	0	0
Methanol	lb/hr	86,498	86,498	86,498	86,498	83,903	2,595	83,903	83,903
DME	lb/hr								
Carbon (Solid)	lb/hr								
Sulfur (Solid)	lb/hr								
Olivine (Solid)	lb/hr								
Wood	lb/hr								
Ash	lb/hr								
Char	lb/hr								
Enthalpy Flow	MMBTU/hr	-3	-2	-2	-3	-3	0	-3	-3
Average Density	lb/ft ³								

Heat Stream No.	MM BTU/hr	Work Stream No.	IHP
QH505A	2.57	WVK501	-3147.8
QH505B	8.46		
QH505C	5.87		
QH505D	50.00		
QCH504B	12.38		
QCH593	0.39		

Eq. No.	Equipment Name	Req.	Spare	Equipment Type
D-500	Methanol Degassing Column	1		DISTILLATION
H-500C	#N/A	#N/A	#N/A	#N/A
H-500R	Methanol Column Reboiler	1		SHELL-TUBE
H-504B	Cooler	1		SHELL-TUBE
H-505A	Pinch HX System	1		DHE U-TUBE
H-505B	Pinch HX System	1		DHE U-TUBE
H-505C	Pinch HX System	1		DHE U-TUBE
H-505D	Pinch HX System	1		DHE U-TUBE
H-593	METHANOL Product Finishing cooler	1		SHELL-TUBE
K-501	Methanol Gas Expander	1		CENTRIFUGAL
P-500B	Deaerator Feed Pump	1	1	CENTRIFUGAL
P-500R	Deaerator Feed Pump	1	1	CENTRIFUGAL
P-592	Alcohol Product Pump	1		CENTRIFUGAL

REV	DESCRIPTION	DATE
A	Thermochemical Design Report	3-20-04
B		8-25-04
C		9-17-04
D		11-17-04
E	IC Ethanol Design Report	12-17-06
F	BTC Design Report	08-22-09

SECTION A500
ALCOHOL PURIFICATION

ISSUE-22-09	16 fluidized bed no	PFD-P850-A502	F
-------------	---------------------	---------------	---

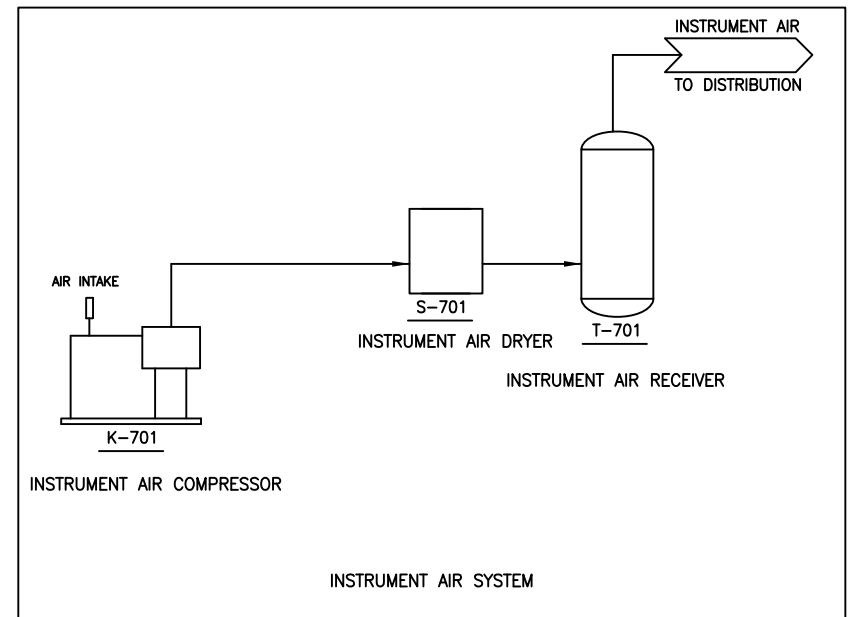
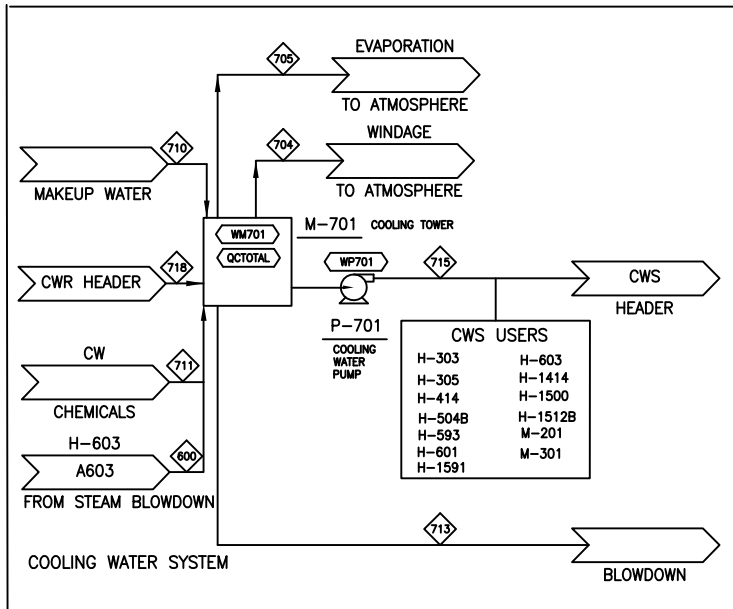

COMPONENT	UNITS	600	704	705	710	711	713	715	718
Total Flow	lb/hr	8,429	#N/A	#N/A	174,716	2	33,450	7,948,667	7,948,667
Temperature	F	111	#N/A	#N/A	60	60	80	80	100
Pressure	Psia	15	#N/A	#N/A	15	15	15	75	60
Vapor Fraction			#N/A	#N/A					
Hydrogen	lb/hr		#N/A	#N/A					
Water	lb/hr	8,429	#N/A	#N/A	174,716	2	33,450	7,948,667	7,948,667
Carbon Monoxide	lb/hr		#N/A	#N/A					
Nitrogen	lb/hr		#N/A	#N/A					
Oxygen	lb/hr		#N/A	#N/A					
Argon	lb/hr		#N/A	#N/A					
Carbon Dioxide	lb/hr		#N/A	#N/A					
Hydrogen Sulfide (H ₂ S)	lb/hr		#N/A	#N/A					
SO ₂	lb/hr		#N/A	#N/A					
Ammonia (NH ₃)	lb/hr		#N/A	#N/A					
NO ₂	lb/hr		#N/A	#N/A					
Methane	lb/hr		#N/A	#N/A					
isobutane	lb/hr		#N/A	#N/A					
n-butane	lb/hr		#N/A	#N/A					
ethane (C ₂ H ₆)	lb/hr		#N/A	#N/A					
ethylene (C ₂ H ₄)	lb/hr		#N/A	#N/A					
acetylene (C ₂ H ₂)	lb/hr		#N/A	#N/A					
Benzene (C ₆ H ₆)	lb/hr		#N/A	#N/A					
Tar (C ₁₀ H ₈)	lb/hr		#N/A	#N/A					
Methanol	lb/hr		#N/A	#N/A					
DME	lb/hr		#N/A	#N/A					
Carbon (Solid)	lb/hr		#N/A	#N/A					
Sulfur (Solid)	lb/hr		#N/A	#N/A					
Olivine (Solid)	lb/hr		#N/A	#N/A					
Wood	lb/hr		#N/A	#N/A					
Ash	lb/hr		#N/A	#N/A					
Char	lb/hr		#N/A	#N/A					
Enthalpy Flow	MMBTU/hr	-1	#N/A	#N/A	-12	0	-2	-548	-546
Average Density	lb/ft ³								

Heat Stream No.	MM BTU/hr	Work Stream No.	IHP
OCTOTAL	182.58	WM701	447.7
		WP701	857.4

Eq. No.	Equipment Name	Req.	Spare	Equipment Type
K-701	Plant Air Compressor	2	1	RECIPROCATING
M-701	Cooling Tower System	1		INDUCED-DRAFT
P-701	Cooling Water Pump	1	1	CENTRIFUGAL
S-701	Instrument Air Dryer	1	1	PACKAGE
T-701	Plant Air Receiver	1		HORIZONTAL-VESSEL

REV	DESCRIPTION	DATE
C	Thermochemical Design Report	8-20-04
D		11-22-04
E	TC Ethanol Design Report	12-17-08
F	BTC Design Report	07-07-09

NATIONAL RENOVABLE ENERGY LABORATORY
 National Bioenergy Center
SECTION A700
COOLING WATER & OTHER UTILITIES
 6 fluidized bed no PFD-P850-A701 F

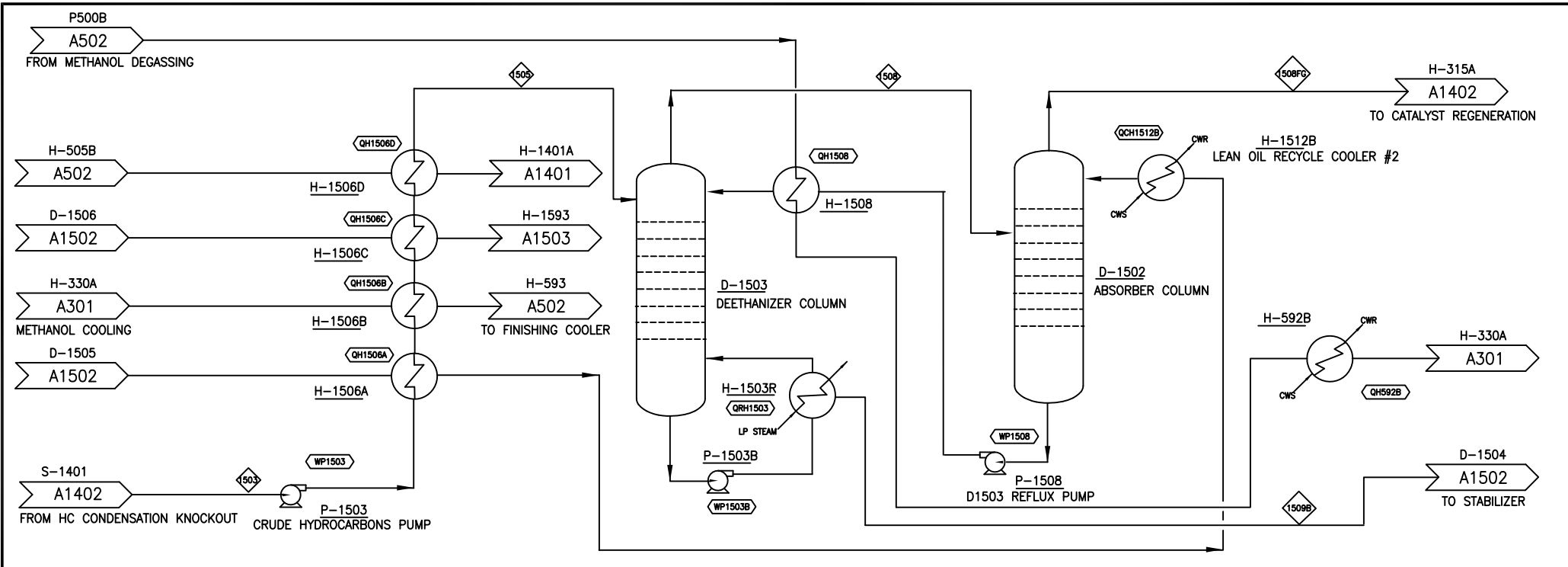

COMPONENT	UNITS	330B	1503	1505	1508	1508FG	1509B
Total Flow	lb/hr	207,127	36,707	36,707	4,479	2,777	37,221
Temperature	F	1621.9	90.00045	200	214.878	70.0062	310.1541
Pressure	Psia	16.5	165.7	252.7	220.0	80.0	220.0
Vapor Fraction		1.00	0.00	0.02	1.00	1.00	0.00
Hydrogen	lb/hr	12,093	1	1	1	1	0
Carbon Dioxide	lb/hr	46,805	0	0	0	0	0
Water	lb/hr	40,662	123	123	20	0	123
Ammonia (NH3)	lb/hr	26	0	0	0	0	0
Methane (CH4)	lb/hr	3,019	228	228	230	228	0
Ethane (C2H6)	lb/hr	4	192	192	201	192	0
Ethylene (C2H4)	lb/hr	658	168	168	174	168	0
Acetylene (C2H2)	lb/hr	60	0	0	0	0	0
Propane (C3H8)	lb/hr	371	1,863	1,863	1,152	999	864
Propene (C3H6)	lb/hr	28	371	371	283	250	121
Isobutane	lb/hr	1,820	2,720	2,720	758	535	2,184
n-butane	lb/hr	379	1,820	1,820	398	229	1,591
Butene	lb/hr	5,345	379	379	94	61	319
Pentane	lb/hr	763	5,345	5,345	540	42	5,515
Pentene	lb/hr	763	763	763	95	1	764
Hexane	lb/hr	765	5,357	5,357	272	46	6,188
Hexene	lb/hr	2,294	765	765	44	8	867
Heptane	lb/hr	1,532	2,294	2,294	54	5	2,592
Heptene	lb/hr	1,532	1,532	1,532	39	3	1,735
Octane	lb/hr	762	762	762	9	0	865
Octene	lb/hr	1,916	1,916	1,916	25	1	2,150
Nonane	lb/hr	762	762	762	4	0	863
Benzene (C6H6)	lb/hr	5	671	671	28	4	768
Toluene	lb/hr	711	711	711	14	1	867
Xylene	lb/hr	3,143	3,143	3,143	24	1	3,519
123TMB	lb/hr	3,489	3,489	3,489	12	0	3,902
1235TMB	lb/hr	0	0	0	0	0	0
1245TMB	lb/hr	274	274	274	0	0	307
ETH-BENZ	lb/hr	292	292	292	3	0	327
Tar (C10H8)	lb/hr	1	0	0	0	0	0
Methanol	lb/hr	0	0	0	0	0	0
DMC	lb/hr	0	0	0	0	0	0
Enthalpy Flow	MMBTUJ	-429	-26	-24	-3	-2	-21
Average Density	lb/ft ³						

Heat Stream No.	MM BTU/hr	Work Stream No.	HP
QH1506A	0.23	WP1503	11.4
QH1506B	0.27	WP1503B	
QH1506C	0.32	WP1508	5.4
QH1506D	1.48		
QH1508	0.17		
QRH1503	-3.11		
QCH1512B	0.17		
QH592B	3.67		

Eq. No.	Equipment Name	Req.	Spare	Equipment Type
D-1502	Absorber Column	1		DISTILLATION
D-1503	Deethanizer Column	1		DISTILLATION
H-1503R	De-ethanizer Column Reboiler	1		SHELL-TUBE
H-1506A	Pinch HX System	1		DHE FIXED T S
H-1506B	Pinch HX System	1		DHE FIXED T S
H-1506C	Pinch HX System	1		DHE FIXED T S
H-1506D	Pinch HX System	1		DHE FIXED T S
H-1508	Pinch HX System	1		DHE FIXED T S
H-1512B	Lean Oil Recycle Cooler #2	1		SHELL-TUBE
P-1503	Crude Hydrocarbons Pump	1		CENTRIFUGAL
H-1503B	D1503 Reboiler Pump	1		CENTRIFUGAL
P-1508	D1503 Reflux Pump	1		CENTRIFUGAL

VER	DESCRIPTION	DATE
A	ETO Design Report	08-29-09
		07-07-09

		NATIONAL RENEWABLE ENERGY LABORATORY	
		National Bioenergy Center	
SECTION A1500 CRUDE GASOLINE SEPARATIONS		#6 fluidized bed no PFD-P850-A1501 A	
		R507-07-09	

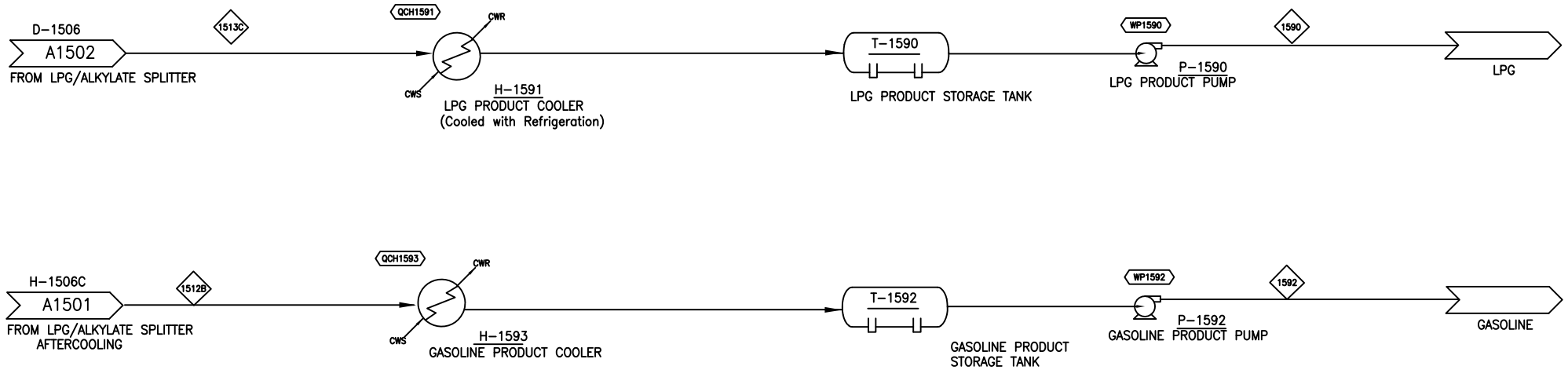

COMPONENT	UNITS	LPG1510	1512B	1590	1592
Total Flow	lb/hr	3,698	13,130	3,698	30,272
Temperature	F	-48.15	237.00	13.05	60.00
Pressure	Psia	35.0	90.0	25.0	14.7
Vapor Fraction		1.00	0.00	0.00	0.00
Hydrogen	lb/hr				
Carbon Dioxide	lb/hr				
Water	lb/hr	0	123	0	123
Ammonia (NH3)	lb/hr				
Methane (CH4)	lb/hr				
Ethane (C2H6)	lb/hr	0		0	0
Ethylene (C2H4)	lb/hr				
Acetylene (C2H2)	lb/hr				
Propane (C3H8)	lb/hr	864		864	0
Propene (C3H6)	lb/hr	121		121	0
Isobutane	lb/hr	1,703	0	1,703	151
n-butane	lb/hr	970	205	970	621
Butene	lb/hr	0			
Pentane	lb/hr	0	5,224	0	5,302
Pentene	lb/hr	0	752	0	752
Hexane	lb/hr		3,320		5,311
Hexene	lb/hr		521		757
Heptane	lb/hr		765		2,289
Heptene	lb/hr		546		1,529
Octane	lb/hr				649
Octene	lb/hr		131		752
Nonane	lb/hr		365		1,914
Nonene	lb/hr		60		752
Benzene (C6H6)	lb/hr		351		657
Toluene	lb/hr		189		710
Xylene	lb/hr		334		3,142
1231MB	lb/hr		123		3,489
1235MB	lb/hr				
1245MB	lb/hr		0		274
ETH-BENZ	lb/hr		39		232
Hex (C6H14)	lb/hr		0		0
Methanol	lb/hr				
DVE	lb/hr				
Enthalpy Flow	MMBTU	-4	-10	-4	-20
Average Density	lb/ft ³				

Heat Stream No.	MMBTU/hr	Work Stream No.	HP
COH1591	0.00	WP1590	
COH1593	2.33	WP1592	1.1

Eq. No.	Equipment Name	Req.	Spare	Equipment Type
H-1591	LPG product cooler - cw	1		SHELL-TUBE
H-1593	Gasoline product cooler - cw	1		SHELL-TUBE
T-1590	LPG Product Storage Tank	1		FLAT-BOTTOM STORAGE
T-1592	Gasoline Product Storage Tank	1		FLAT-BOTTOM STORAGE
P-1590	LPG Product Pump	1		CENTRIFUGAL
P-1592	Gasoline Product Pump	1		CENTRIFUGAL

VER	DESCRIPTION	DATE
A	BTG Design Report	06-29-09
		07-13-09

NATIONAL RENEWABLE ENERGY LABORATORY

National Bioenergy Center

SECTION A1500

PRODUCT COOLING AND STORAGE

16 ft liquidized bed reactor	PFD-P850-A1503	A
------------------------------	----------------	---

Appendix I. Comparison to other Biomass-to-Gasoline and Methanol-to-Gasoline Published Costs

I.1 Comparison to “Techno-economic Analysis for the Conversion of Lignocellulosic Biomass to Gasoline via the Methanol-to-Gasoline (MTG) Process” by S. B. Jones and Y. Zhu from Pacific Northwest National Laboratory (PNNL)

The report “Techno-economic Analysis for the Conversion of Lignocellulosic Biomass to Gasoline via the Methanol-to-Gasoline (MTG) Process” by S. B. Jones and Y. Zhu from Pacific Northwest National Laboratory (PNNL) predicts a plant gate price (PGP) that is approximately 65% higher than the PGP predicted in the NREL BTG study. A principal difference between the two studies is the state of the various technologies throughout the process. PNNL’s report utilizes and references proven states of technology. The report by NREL analyzes future states of the technologies and predicts the potential of the process. For the gasification and syngas cleanup sections in the NREL report, the 2012 targets used were set by DOE and are defined in the OBP MYPP (Multi-Year Program Plan). In the MTG section of the NREL report, a fluidized bed reactor was utilized (proven at the pilot scale) instead of the fixed bed reactor utilized by PNNL (proven at the commercial scale). The states of technologies have a large impact on the capital and operating costs required for the process. Other differences include but are not limited to stream factor, year dollars used (2007 vs. 2008), and feedstock cost.

In the table below, the PNNL assumptions are imposed on the NREL model cumulatively and the price per gallon gasoline calculated.

Table I-1. Comparison of NREL and PNNL Model Assumptions and Effect on PGP

	Assumptions (NREL→PNNL)	NREL Price per Gallon	PNNL Price per Gallon
Original Cases		1.95	3.20
LPG Contribution by Energy Value or Co-Product Credit	Energy Value→Co-Product Credit	1.96	
Years Dollars Used	2007→2008	2.06	
Feedstock Cost	\$50.70→\$60.00	2.21	
Stream Factor	0.96→0.90	2.29	
Total Project Investment	\$213M→\$336M ^a	3.03	
Electricity Purchase	0→1.52 kWh/gallon	3.14	
Other		3.20	

^a 54% of the difference in Total Project Investment is attributed to the front end of the process (including feed handling, drying, gasification, tar reforming, quench, acid gas removal, and syngas compression) while 46% is attributed to the back end of the process (including methanol synthesis, MTG process, and gasoline refining).

Explanations and other differences:

1. Some of the equipment cost differences in the syngas cleanup section are due to an additional steam reformer used by PNNL; this steam reformer was removed from NREL analysis designs when tar reformer targets were met.
2. Equipment cost differences for the methanol-to-gasoline process include differences in the types of MTG reactors chosen. NREL selected a fluidized bed reactor, while PNNL

selected a fixed bed reactor. The fixed bed case requires a 7.5:1 gas recycle loop to the reactor for heat management purposes. This very large recycle results in overall higher costs.

3. The tar reformer conversions in the 2012 State of Technology targets set by the U.S. Department of Energy represent a prediction of tar reforming capabilities in the near future. The tar reformer conversions used in the PNNL report are cited from Spath et al. (2005) and are more representative of demonstrated technology in 2005. Improvements in tar/methane reforming technology are currently being developed and demonstrated at NREL.
4. Other differences not listed in the table above include:
 - A. The NREL report includes an alkylation unit to convert 2-butene and isobutane into isooctane, resulting in 2% higher gasoline yields.
 - B. The NREL report uses a dedicated water gas shift reactor to obtain the correct H₂:CO ratio for the methanol reactor.
 - C. The NREL report includes greater methanol recovery after the methanol reactor by using a product recovery system that includes a multiple flash drum configuration.
 - D. The process in the NREL report produces all of the necessary electricity for the process. The PNNL design requires more than 7 MW of electricity to be purchased from the grid, accounting for \$0.13 of PNNL's minimum fuel selling price (MFSP).

I.2 Comparison of Total Project Investment to Published Cost Information from the New Zealand MTG Commercial Plant (Seddon 2006)

A report by Seddon (2006) gives some financial insight into the New Zealand MTG commercial plant. It states that the total cost was \$1,475 million in 1985 U.S. dollars (\$2,900 million in 2007 U.S. dollars). It also states that 40% of this cost was directly from interest and inflation and thus it is assumed that the total project investment (TPI) is \$1,740 million in 2007 U.S. dollars. The New Zealand plant (200 million gallons per year, Seddon 2006) is approximately 4.5 times larger than the BTG plant (43 million gallons per year). Other cost increasing factors include:

- It was built on an active volcano and thus required extensive engineering and expensive infrastructure mitigation for seismic activity.
- It was a first of a kind plant, and a first of a kind plant typically costs double what an nth plant costs.

Appendix J. External Reviewer Comments and Responses

Thank you to our external reviewers: Peter Tijm, Dr. Robert Brown, Dr. Nicholas Petrellis, Jim Wykowski, and Dave Payton. We worked to address all comments and suggestions as described in the ‘Response’ column.

<p>General Comments:</p> <ul style="list-style-type: none"> • Stated that yields and efficiencies were consistent with what he had expected. • Thought the work looked thorough and well done. • Asked what percentage of capital costs were for the syngas, and was pleased with the response of 76%. • Questioned what temperature was in the low temperature shift reactor and if the steam entering is superheated or not. He was satisfied with response of 750°F and the steam is superheated. • Reviewed overall report and focused on MTG part as requested. • Report uses same feedstock, nth plant, detailed design, and economic analysis approaches as other NREL reports. • Using nth plant basis reportedly helps in guiding research. However doesn’t tend to highlight uncertainties and barriers to commercial development and readiness. Estimated cost uncertainties for individual technologies make comparisons between technologies problematic unless the differences are overwhelming. 	
Suggestion/Comment	Response
Thought the process would most likely need a guard bed ahead of the tar reformer containing the nickel-based catalyst.	A sensitivity was performed finding that there was no change in the PGP if a guard bed was added to the process.
Suggested that the economics could possibly be improved by selling the crude gasoline, which then could be sent to a refinery (potential to save capital).	Added to ‘Conclusion’ as a ‘Future work area of interest.’
Estimated that feedstock actually costs approximately \$75/ton.	The feedstock cost is set in the OBP MYPP and remains \$50.70/ton. However, a sensitivity is included for feedstock cost in Section 4.2.
Noted that he saw room for refinement opportunities in the thermal analysis.	Added to ‘Conclusion’ as a ‘Future work area of interest.’
Suggested a 10% IRR is too low for companies to invest.	10% IRR is standard in NREL Design Reports and in order to maintain consistency will be kept at 10%. However, there is a sensitivity included in Section 4.2 addressing Internal Rate of Return.
Suggested including information of recent MTG processes (DKRW – Wyoming and Synthesis Energy Systems).	Information included in Section 1.1.

Suggested noting butane and 1,2,4,5-tetramethylbenzene differences in Appendix B.	Appendix B was revisited and corrected. An error was caught that the refined gasoline stream from the Aspen simulation was listed when the crude gasoline composition should have been listed.
Suggested incorporating some information on Exxon Mobil's licensing fees for the MTG process.	Exxon Mobil's licensing department was contacted. However, they were unable to release any cost-related information.
Suggested decreasing the range of olivine and tar reformer costs in the sensitivity chart.	Ranges were decreased.
Suggested updating the acronym list.	List was updated.
Suggested including a PGP or price difference if methane conversion was the proven level of 50%.	The PGP of \$2.05 including current tar reforming capabilities was included in the report in Section 2.3.
Noted PFD a402 was used when a403 should have been referenced.	Correction was made.
Suggested adding capacity to beginning of Executive Summary.	Added capacity to Executive Summary.
Noted that economies of scale are not always applicable, especially for very large scale equipment.	Sizing factors were not changed in order to maintain consistency with NREL Design Reports.
Suggested diesel price was far too low.	Increased diesel fuel cost to \$63,626 cents/ton (\$2.20/gallon).
Suggested clarifying ton vs. tonne.	Ton is now specified as U.S. Ton and Tonne is now specified as Metric Tonne.
Questioned if the foundation of the work in the Ethanol Design Report was targeting Ethanol or Mixed Alcohols.	It is now specified in Section 1.1 that the work done for the Ethanol Design Report was for ethanol via a mixed alcohol catalyst with subsequent separation.
Stated that truck delivery of biomass was not practical for a 2,000 tonne/day facility.	Train is now mentioned in Section 2.1 as an attractive alternative.
Suggested adding the stoichiometric number to Table 8 and Table 10.	Stoichiometric numbers have been added to tables 8 and 10.
Suggested looking again at H ₂ S concentrations in gas emitted from LO-CAT system.	The H ₂ S emissions were revisited and a reference is now provided. Additional polishing of effluent, if needed, is not expected to impact economics significantly.
Suggested making continuous the biomass-to-gasoline process, without using a tank for the methanol.	The design is set up for the process to be continuous with the possibility to store methanol prior to the MTG section. This is done in order to accommodate upsets or possibly buying methanol when market conditions allow for use during upsets to methanol production.

Noted that LPG is marketable as is.	Wording was changed to reflect this.
Suggested adding an extra firewater pump and tank.	Done.
Suggested increasing the number of plant engineers from 1 to 2.	Done.
Suggested increasing the number of lab technicians from 2 to 4.	Done.
Somewhere in the report it would be good to highlight major opportunities to improve the cost of BTG and where the major technology development challenges will lie.	Included throughout the report, and is highlighted in the Executive Summary and Conclusions.
An n th plant means a mature industry and so feedstock is likely to be purpose-grown energy crop. Total cost of feedstock is expected to be higher than \$50.7/ ton used based on our recent study.	The feedstock cost is set in the OBP MYPP and remains \$50.70/ton. However, a sensitivity is included for feedstock cost in Section 4.2.
Even in a mature plant case, the project contingency as a percent of total installed cost is tiny compared to what most industrial companies use even for mature technologies. The assumed service factor of 96% seems high particularly for process that has significant amount of solids handling.	There is a sensitivity included in Section 4.2 addressing stream (service) factor.
Recent peer/industry review of biomass gasification seems to indicate high costs. In particular I believe gas cleanup is an issue. Believe this review was published in December Energy issue. I haven't seen this but NREL should check how that report compares to this and possibly acknowledge major differences if they exist.	The cost of equipment, including gas cleanup equipment, is consistent with previous NREL reports. Efforts have been made at NREL to find appropriate equipment costs. Also, Section 4.2, within the sensitivity analysis, shows effect on PGP if the total project investment is varied.
Report uses thermal (BTU) basis to allocate prices to gasoline and LPG products. Alternate would be to use LPG market price and see what gasoline price results.	In Section 3, a market price for propane is given and compared to the LPG price yielded by this method.
Has MTG ever used syngas from wood gasification? Carry over of contaminants or impurities are potential problems for downstream catalysts. Is it understood how to deal with this issue? Sensitivity to catalyst life should be tested.	In Section 5 it is stated that a future area of work would be to test the MTG reactor and catalyst with methanol from biomass-derived syngas.

<p>What is commercial status of fluid bed MTG? Issue is uncertainties around design, cost to build, and cost to operate. Fluid bed vs. fixed bed will have significant conversion differences that do not appear to be recognized. Fluid bed will not provide as much staging and will have lower yield than fixed bed. A sensitivity to using fixed vs. fluid bed should be included.</p>	<p>A sensitivity for using fixed bed vs. fluid bed for a constant assumed conversion is included in Section 4.2 Methanol and Methanol-to-Gasoline. Compositions of several published MTG gasolines are compared with the Aspen simulation composition in Appendix B.</p>
<p>The report cites a quote to build a facility to take natural gas to gasoline via methanol of \$2.9B (2007 \$). Is there a reference for this? Assuming it is a valid quote, even after adjusting for plant size, this would suggest \$1B for a 2,000 t/d size plant in the NREL report. Presumably the quote captures what was learned in the NZ demonstration plant. I wouldn't expect an nth plant basis to reduce this cost by more than 50% (\$0.5B) and it would take years of continuous improvement. I would also expect the investment cost to make syngas from wood to be higher than making syngas from natural gas. The NREL report shows an investment of \$0.2 B which is significantly lower. This will be a major red flag for prospective participants in this technology.</p>	<p>Reference of Seddon 2006 is given. The numbers were recalculated and the summary was rewritten to be more clear and concise. The New Zealand plant had several factors that contributed to higher costs in addition to being a first of a kind plant. See Appendix I.</p>
<p>Figure 8 axis labeling does not match with individual figure in chart. The individual figures total 1.93 which corresponds to gasoline price per gallon. The axis refers to \$/MM BTU.</p>	<p>The axis of Figure 8 has been corrected.</p>
<p>The sensitivity analysis starting on page 38 helps to highlight areas of uncertainty. NREL might say more about what the bases for variation are in the words that follow the table. Some of the ranges shown are low, especially feedstock and total project investment.</p>	<p>The sensitivity parameters for TPI and feedstock were increased. For feedstock the upper limit was \$70/ton and it is now \$85/ton. For TPI the upper limit was \$230MM and now it is \$500MM.</p>
<p>Some of this discussion should be included in the executive summary. The summary should show ranges of costs and yields...precision implied by single number with two significant figures misrepresents the situation...is very misleading.</p>	<p>The Executive Summary now more explicitly explains that the PGP is for the base case and the sensitivity analysis is provided for the reader to view the PGP changes with variations in specified parameters.</p>

<p>This process is very sensitive to the cost of feedstock...and therefore the overall yields. It would be useful to provide overview of yield assumptions for each part of plant and a comparison with actual currently demonstrated yields.</p>	<p>Gasifier: Yields are well known based on experimental and published results. Tar Reformer: A sensitivity is presented in Sections 2.3 and 4.2 based on lower tar reformer conversions. Methanol Synthesis: Yields are well known and are based on published information. Methanol-to-Gasoline: A sensitivity is included in Section 4.2 on decreased gasoline yields.</p>
<p>On p. 97 a comparison is made between PNNL's and NREL's report on BTG. I have not seen the PNNL report. The differences and consequences are indicated in the NREL report. In some cases the differences are pretty straightforward. However, the uninstalled cost difference is quite large, \$84M for PNNL and \$37M for NREL. More discussion about the bases and uncertainties which drive the differences and the implications for commercial readiness would be useful.</p>	<p>The comparison has been elaborated. See Appendix I.</p>

REPORT DOCUMENTATION PAGE

Form Approved
OMB No. 0704-0188

The public reporting burden for this collection of information is estimated to average 1 hour per response, including the time for reviewing instructions, searching existing data sources, gathering and maintaining the data needed, and completing and reviewing the collection of information. Send comments regarding this burden estimate or any other aspect of this collection of information, including suggestions for reducing the burden, to Department of Defense, Executive Services and Communications Directorate (0704-0188). Respondents should be aware that notwithstanding any other provision of law, no person shall be subject to any penalty for failing to comply with a collection of information if it does not display a currently valid OMB control number.

PLEASE DO NOT RETURN YOUR FORM TO THE ABOVE ORGANIZATION.

1. REPORT DATE (DD-MM-YYYY) January 2011		2. REPORT TYPE Technical Report		3. DATES COVERED (From - To)	
4. TITLE AND SUBTITLE Gasoline from Wood via Integrated Gasification, Synthesis, and Methanol-to-Gasoline Technologies			5a. CONTRACT NUMBER DE-AC36-08GO28308		
			5b. GRANT NUMBER		
			5c. PROGRAM ELEMENT NUMBER		
6. AUTHOR(S) S.D. Phillips, J.K. Tarud, M.J. Bidy, and A. Dutta			5d. PROJECT NUMBER NREL/TP-5100-47594		
			5e. TASK NUMBER BB07.3710		
			5f. WORK UNIT NUMBER		
7. PERFORMING ORGANIZATION NAME(S) AND ADDRESS(ES) National Renewable Energy Laboratory 1617 Cole Blvd. Golden, CO 80401-3393			8. PERFORMING ORGANIZATION REPORT NUMBER NREL/TP-5100-47594		
9. SPONSORING/MONITORING AGENCY NAME(S) AND ADDRESS(ES)			10. SPONSOR/MONITOR'S ACRONYM(S) NREL		
			11. SPONSORING/MONITORING AGENCY REPORT NUMBER		
12. DISTRIBUTION AVAILABILITY STATEMENT National Technical Information Service U.S. Department of Commerce 5285 Port Royal Road Springfield, VA 22161					
13. SUPPLEMENTARY NOTES					
14. ABSTRACT (Maximum 200 Words) This report documents the National Renewable Energy Laboratory's (NREL's) assessment of the feasibility of making gasoline via the methanol-to-gasoline route using syngas from a 2,000 dry metric tonne/day (2,205 U.S. ton/day) biomass-fed facility. A new techno-economic model was developed in Aspen Plus for this study, based on the model developed for NREL's thermochemical ethanol design report (Phillips et al. 2007). The necessary process changes were incorporated into a biomass-to-gasoline model using a methanol synthesis operation followed by conversion, upgrading, and finishing to gasoline. Using a methodology similar to that used in previous NREL design reports and a feedstock cost of \$50.70/dry ton (\$55.89/dry metric tonne), the estimated plant gate price is \$16.60/MMBtu (\$15.73/GJ) (U.S. \$2007) for gasoline and liquefied petroleum gas (LPG) produced from biomass via gasification of wood, methanol synthesis, and the methanol-to-gasoline process. The corresponding unit prices for gasoline and LPG are \$1.95/gallon (\$0.52/liter) and \$1.53/gallon (\$0.40/liter) with yields of 55.1 and 9.3 gallons per U.S. ton of dry biomass (229.9 and 38.8 liters per metric tonne of dry biomass), respectively.					
15. SUBJECT TERMS biomass; gasoline; methanol; thermochemical; syngas; techno-economic; advanced biofuels; gasification; biomass to gasoline; BTG; methanol to gasoline; MTG; plant gate price; ethanol.					
16. SECURITY CLASSIFICATION OF:			17. LIMITATION OF ABSTRACT UL	18. NUMBER OF PAGES	19a. NAME OF RESPONSIBLE PERSON
a. REPORT Unclassified	b. ABSTRACT Unclassified	c. THIS PAGE Unclassified			19b. TELEPHONE NUMBER (Include area code)